

4

3

2

1

REVISIONS				
ZONE	REV.	DESCRIPTION	DATE	APPROVED
C3	A	Length Updated for Manufacturer	10/29/2024	JO

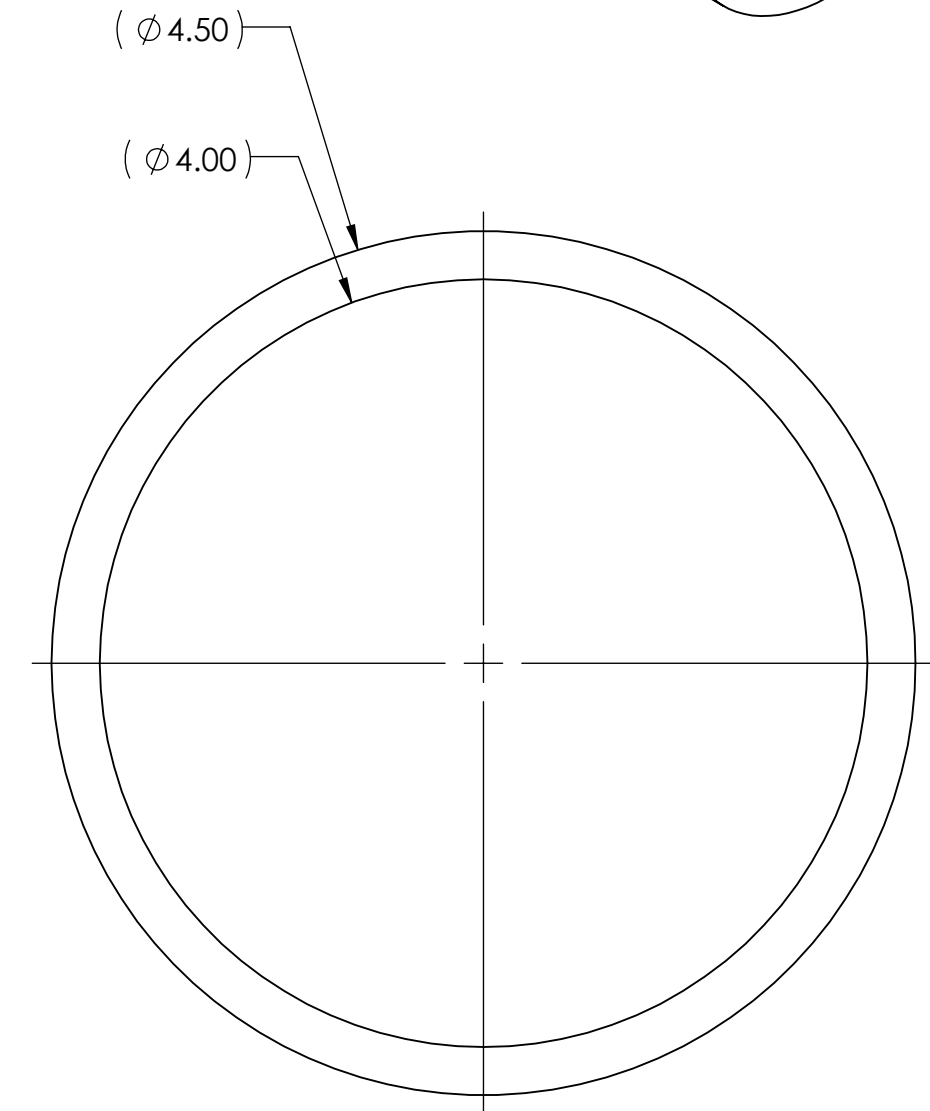
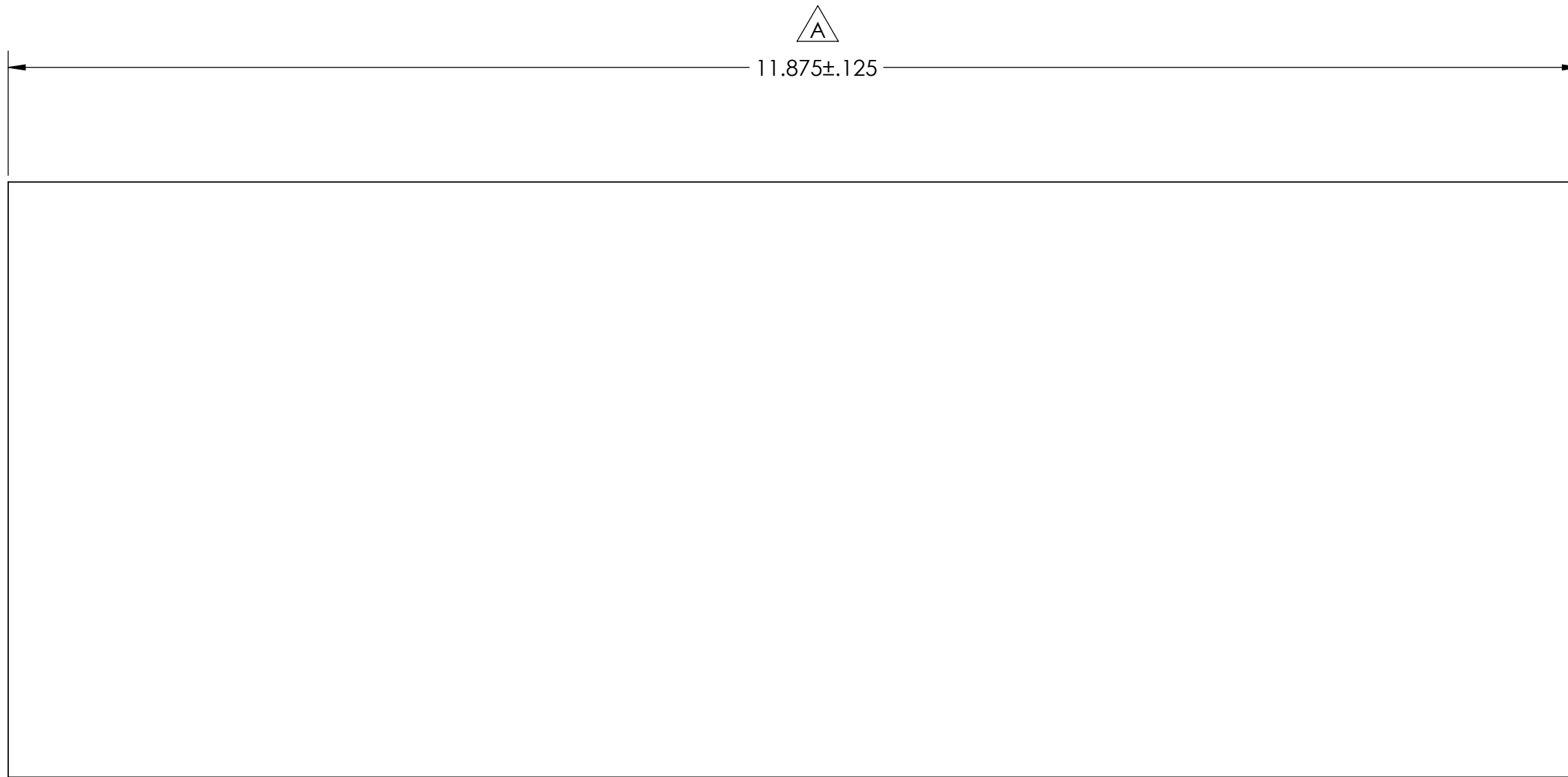
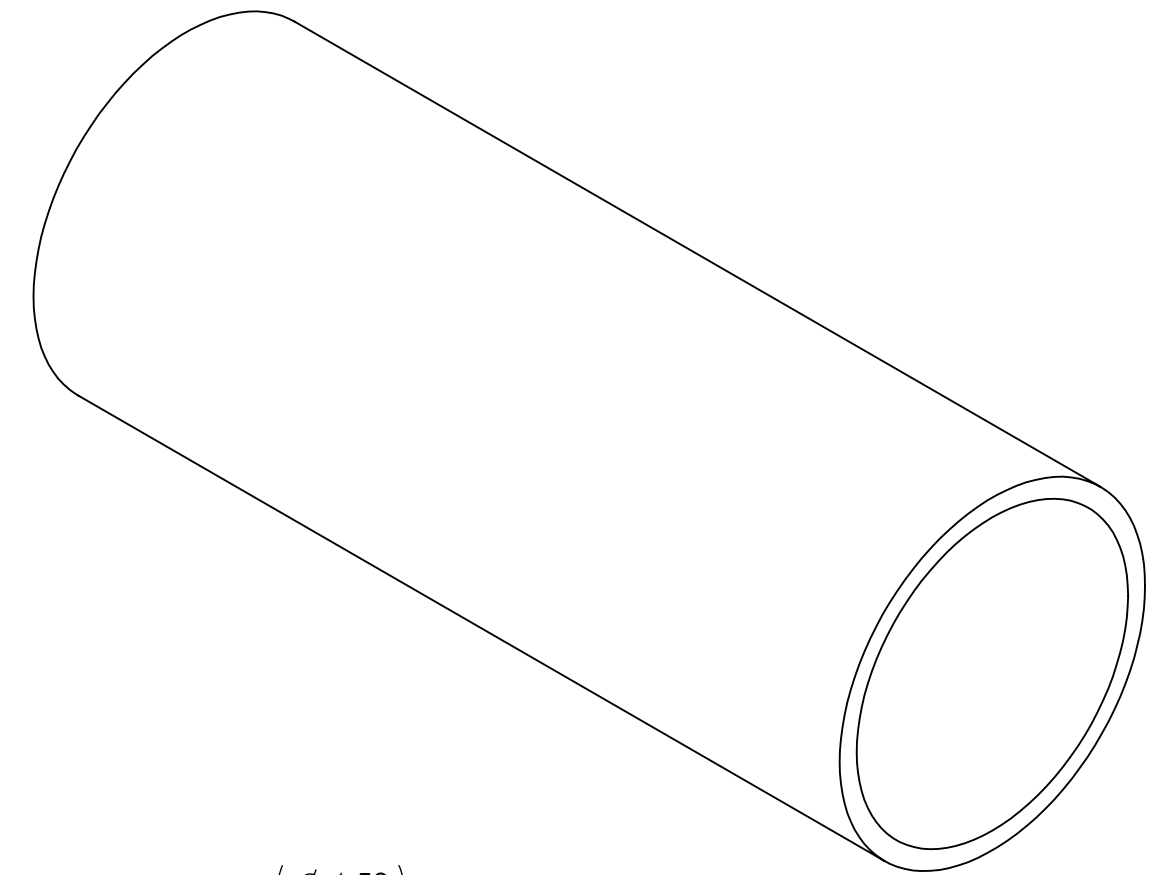

UNLESS OTHERWISE SPECIFIED:

DIMENSIONS ARE IN INCHES
 TOLERANCES:
 FRACTIONAL ± 1/16
 ANGULAR: MACH ± 1° BEND ± 1°
 TWO PLACE DECIMAL ± .01
 THREE PLACE DECIMAL ± .005

MATERIAL/FINISH:
 4" Schedule 40 PVC Foam
 Core DWV Pipe

DO NOT SCALE DRAWING

VEND	NAME	DATE
DRAWN	JO	9/6/2024

PROPRIETARY AND CONFIDENTIAL
 THE INFORMATION CONTAINED IN
 THIS DRAWING IS THE SOLE
 PROPERTY OF **FIRST®**. ANY
 REPRODUCTION IN PART OR AS A
 WHOLE WITHOUT THE WRITTEN
 PERMISSION OF **FIRST®** IS
 PROHIBITED.

COMMENTS:
 REMOVE ALL BURRS AND SHARP
 EDGES.



TITLE:
Coral

SIZE	DWG. NO.	REV
C	GE-25500	A

SCALE: 1:1 SHEET 1 OF 1

4

3

2

1

D

D

C

C

B

B

A

A

4

3



2

1

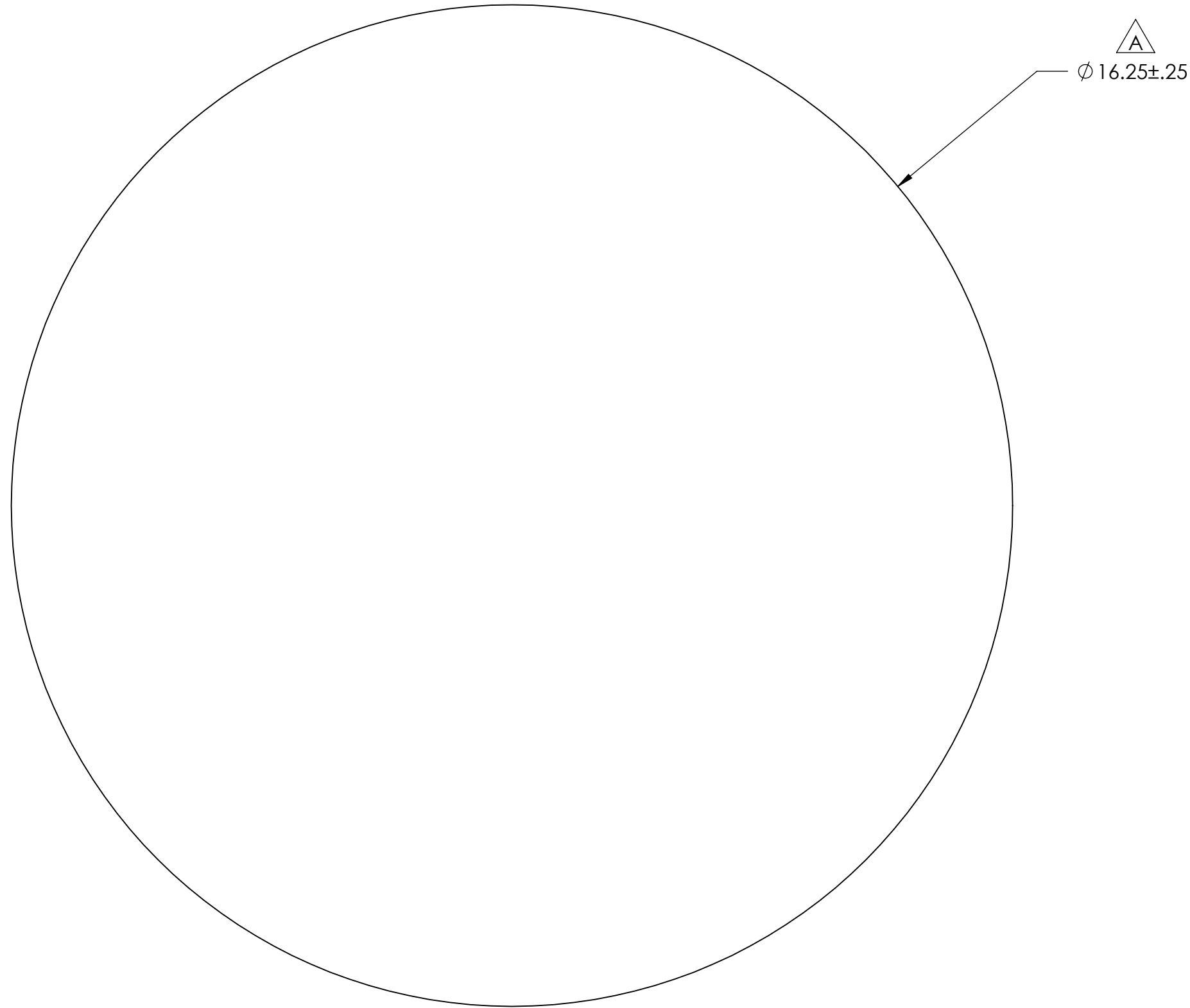
REVISIONS				
ZONE	REV.	DESCRIPTION	DATE	APPROVED
D2	A	Size increased by 0.25" and tolerance tightened	1/9/2025	JO



Original vendor: Baden
Resold by AndyMark

UNLESS OTHERWISE SPECIFIED: DIMENSIONS ARE IN INCHES TOLERANCES: FRACTIONAL ±1/16 ANGULAR: MACH ±1° BEND ±1° TWO PLACE DECIMAL ±.01 THREE PLACE DECIMAL ±.005 MATERIAL/FINISH: 16" Playground Ball DO NOT SCALE DRAWING	VEND	NAME	DATE	 
	DRAWN	JO	12/18/2024	
PROPRIETARY AND CONFIDENTIAL				TITLE: <h1>Algae</h1>
THE INFORMATION CONTAINED IN THIS DRAWING IS THE SOLE PROPERTY OF FIRST® . ANY REPRODUCTION IN PART OR AS A WHOLE WITHOUT THE WRITTEN PERMISSION OF FIRST® IS PROHIBITED.				
COMMENTS:				SIZE C
REMOVE ALL BURRS AND SHARP EDGES.				DWG. NO. GE-25501
				REV A
				SCALE: 1:2
				SHEET 1 OF 1

4

3

2

1

D

D

C

C

B

B

A

A