

4

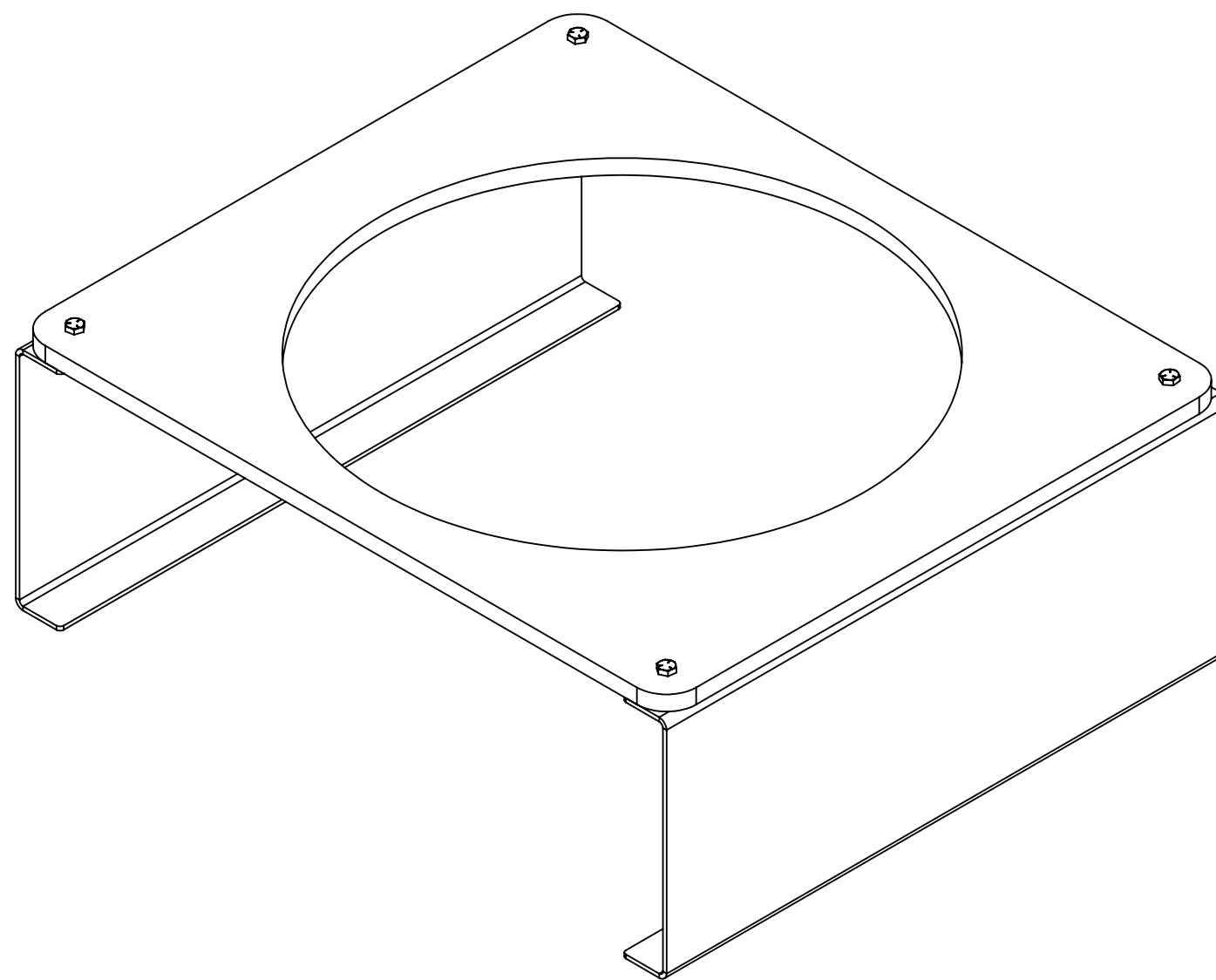
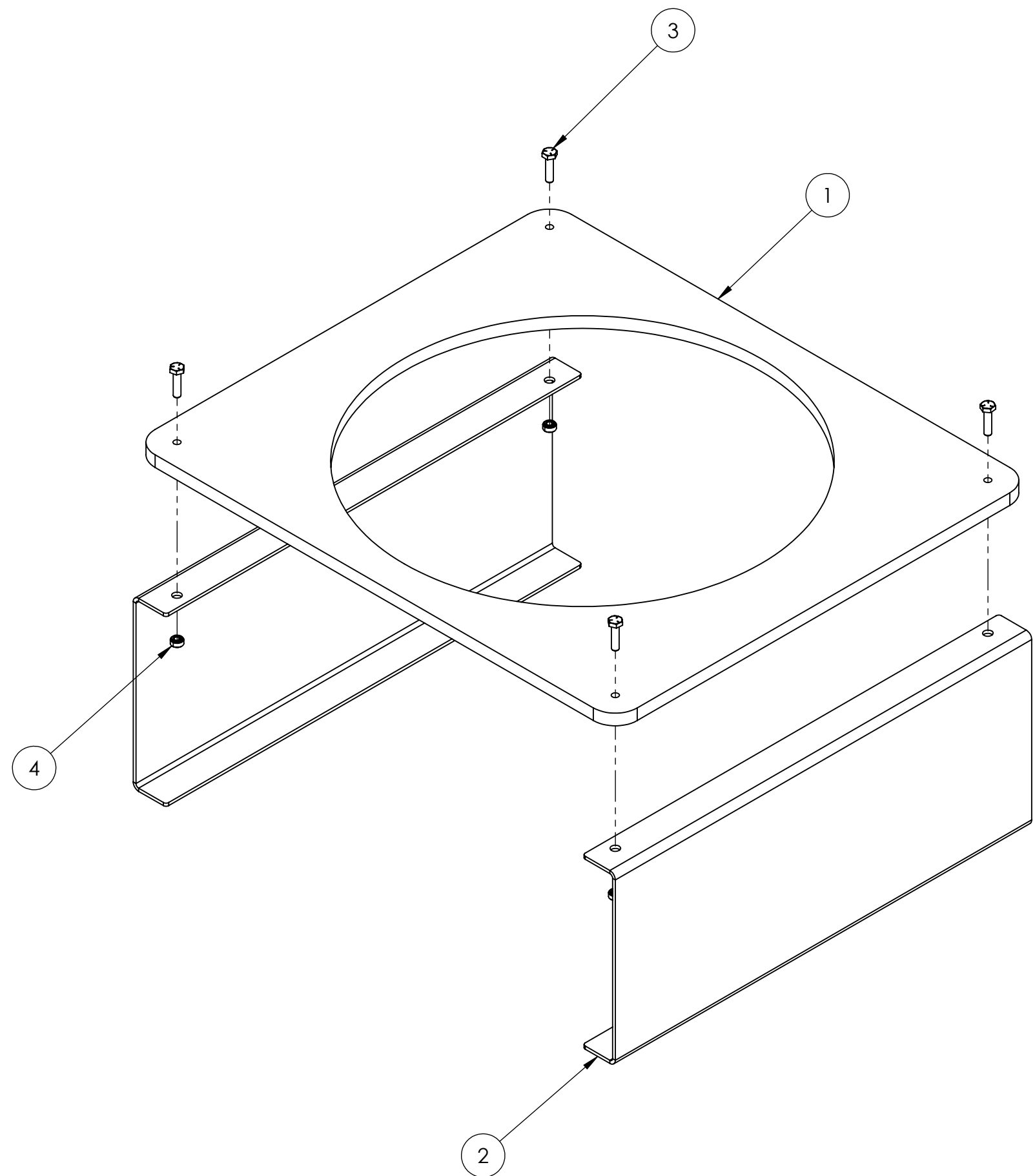

3

2

1



ITEM NO.	PART NUMBER	DESCRIPTION	QTY.
1	GE-25421	Algae Inflation Jig Panel	1
2	GE-25422	Algae Inflation Jig Foot	2
3	Configurable Bolt	1" Long 1/4-20 Hex Head Bolt	4
4	pem_clinchnut_.25_20 _.054	1/4-20 self-clinching nut, .054 shank	4

UNLESS OTHERWISE SPECIFIED: DIMENSIONS ARE IN INCHES TOLERANCES: FRACTIONAL ±1/16 ANGULAR: MACH ±1° BEND ±1° TWO PLACE DECIMAL ±.01 THREE PLACE DECIMAL ±.005 MATERIAL/FINISH: DO NOT SCALE DRAWING	VEND	NAME	DATE	 
	DRAWN	JO	1/9/2025	
	PROPRIETARY AND CONFIDENTIAL			TITLE: <h2 style="text-align: center;">Algae Inflation Jig</h2>
	THE INFORMATION CONTAINED IN THIS DRAWING IS THE SOLE PROPERTY OF FIRST® . ANY REPRODUCTION IN PART OR AS A WHOLE WITHOUT THE WRITTEN PERMISSION OF FIRST® IS PROHIBITED.			
	COMMENTS:			SIZE DWG. NO. REV C GE-25420
	REMOVE ALL BURRS AND SHARP EDGES.			SCALE: 1:4 SHEET 1 OF 1

4

3

2

1

D

D

C

C

B

B

A

A

4

3

2

1

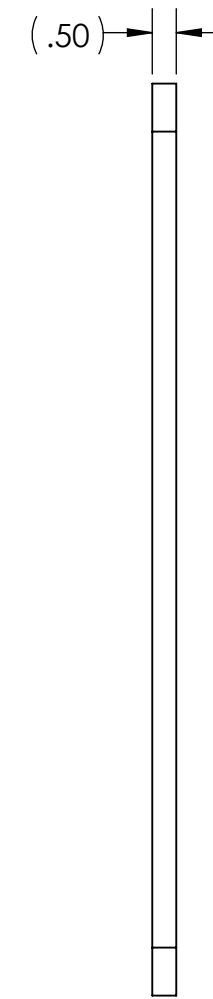
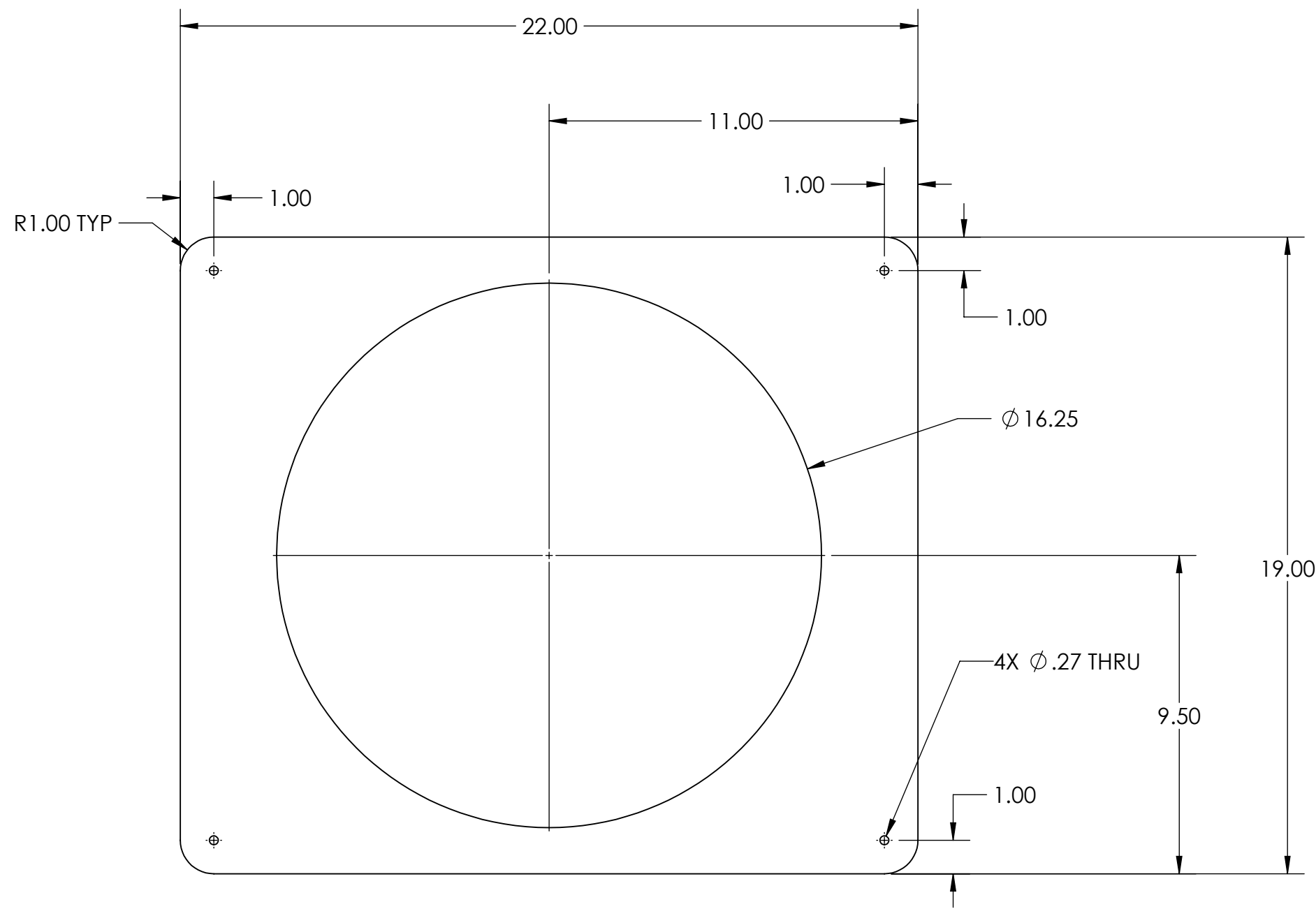
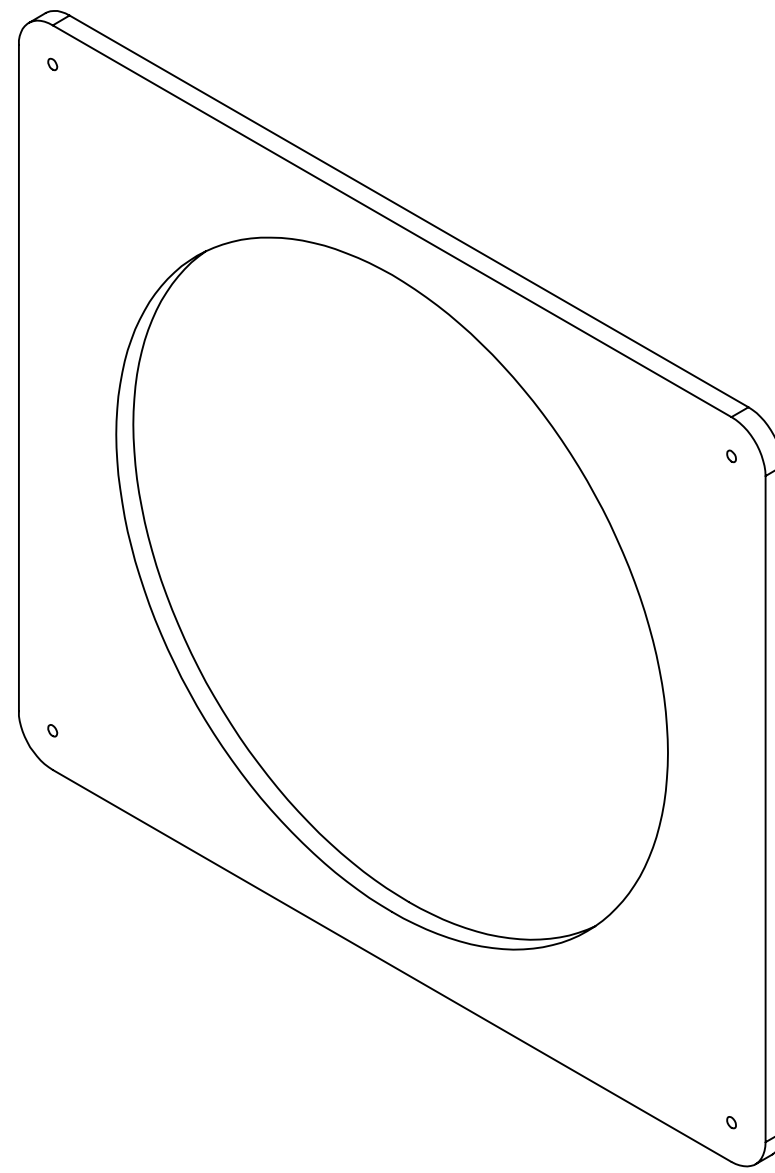

UNLESS OTHERWISE SPECIFIED:
 DIMENSIONS ARE IN INCHES
 TOLERANCES:
 FRACTIONAL ± 1/16
 ANGULAR: MACH ± 1° BEND ± 1°
 TWO PLACE DECIMAL ± .01
 THREE PLACE DECIMAL ± .005

MATERIAL/FINISH:
 1/2" HDPE Matte Finish

DO NOT SCALE DRAWING

VEND	NAME	DATE
DRAWN	JO	1/9/2025
PROPRIETARY AND CONFIDENTIAL		
THE INFORMATION CONTAINED IN THIS DRAWING IS THE SOLE PROPERTY OF FIRST ®. ANY REPRODUCTION IN PART OR AS A WHOLE WITHOUT THE WRITTEN PERMISSION OF FIRST ® IS PROHIBITED.		
COMMENTS: REMOVE ALL BURRS AND SHARP EDGES.		



TITLE: Algae Inflation Jig Panel		
SIZE	DWG. NO.	REV
C	GE-25421	
SCALE: 1:4		SHEET 1 OF 1

D

D

C

C

B

B

A

A

4

3

2

1

4

3

2

1

D

D

C

C

B

B

A

A

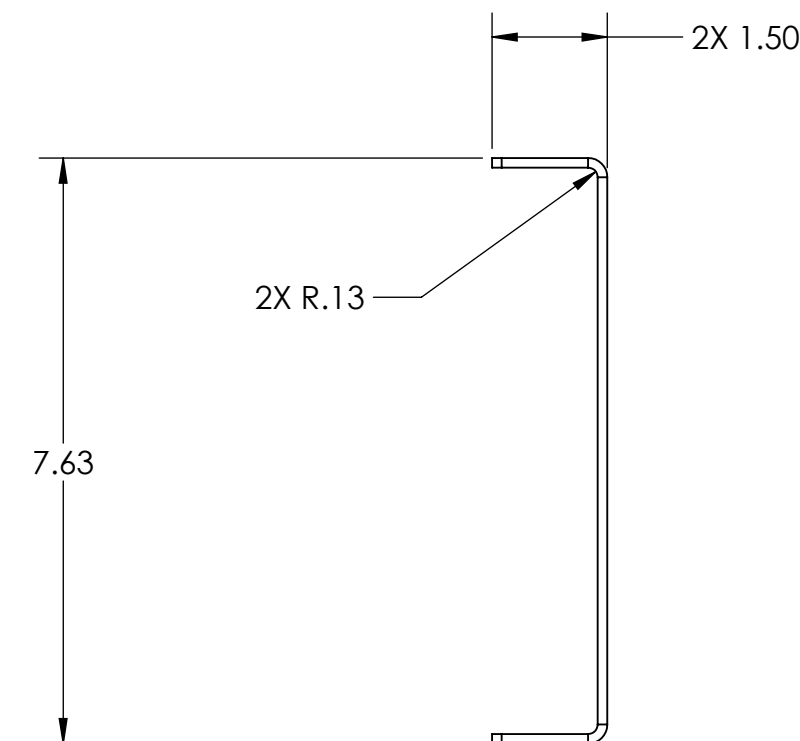
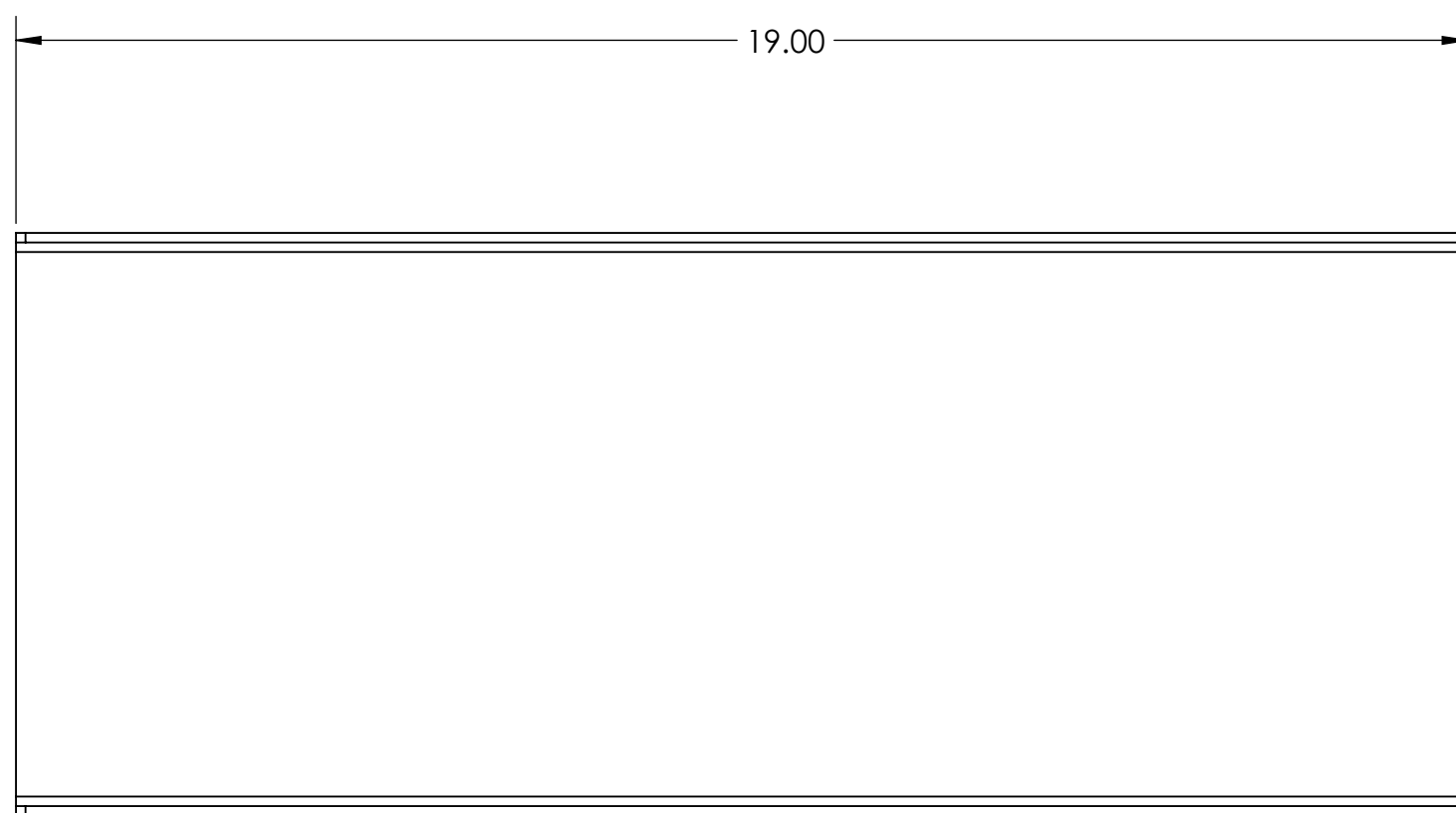
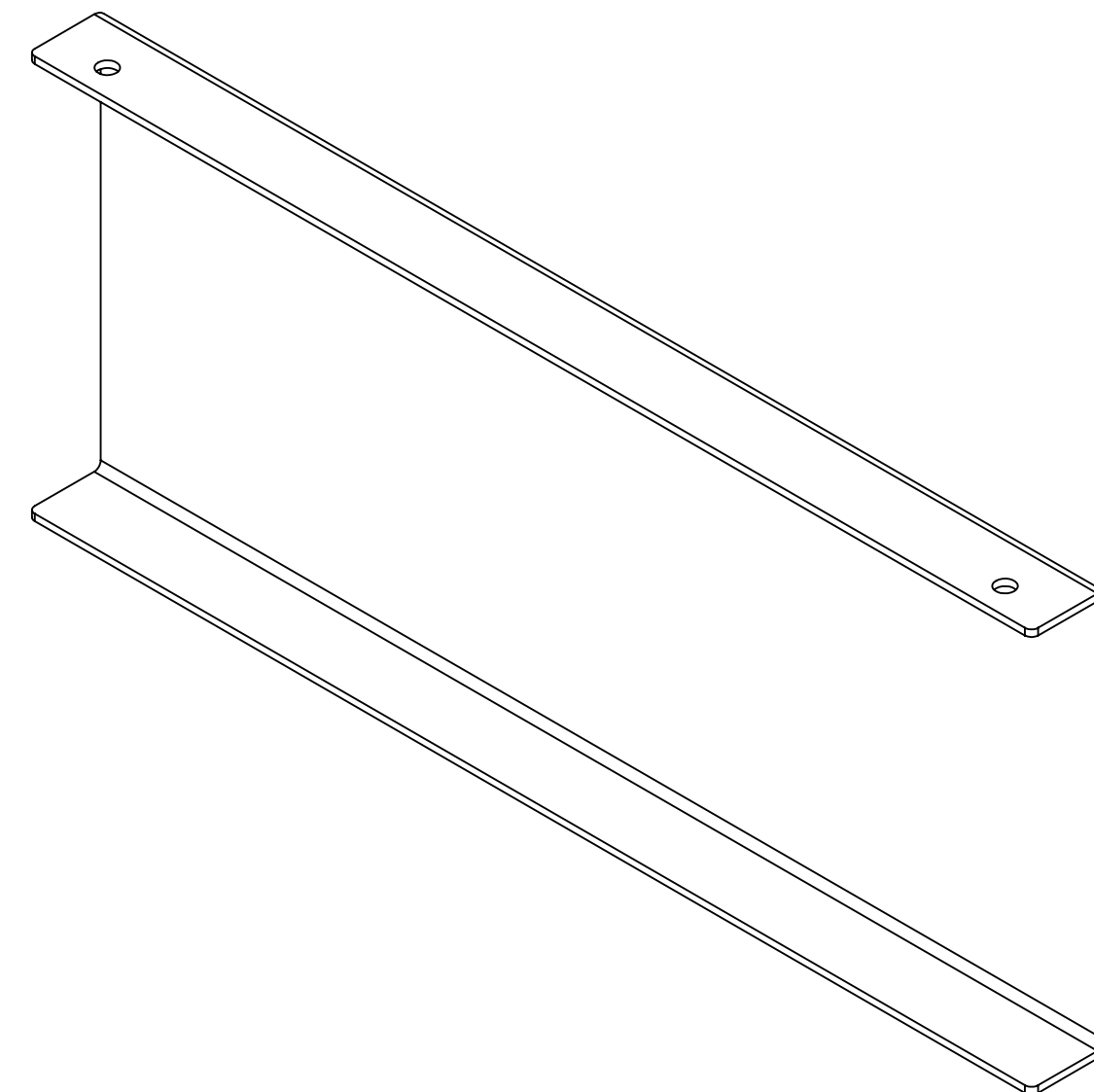
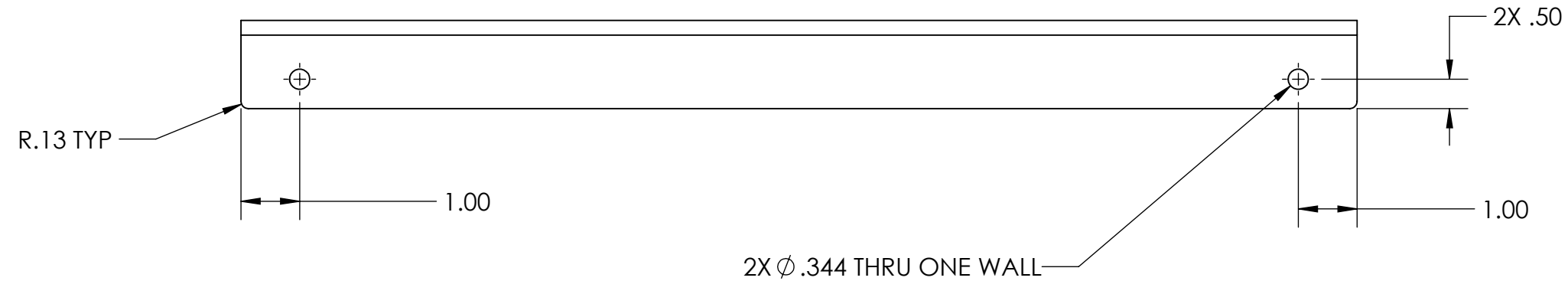

UNLESS OTHERWISE SPECIFIED:

DIMENSIONS ARE IN INCHES
 TOLERANCES:
 FRACTIONAL $\pm 1/16$
 ANGULAR: MACH $\pm 1^\circ$ BEND $\pm 1^\circ$
 TWO PLACE DECIMAL $\pm .01$
 THREE PLACE DECIMAL $\pm .005$

MATERIAL/FINISH:
 1/8" 5052 Aluminum

DO NOT SCALE DRAWING

VEND	NAME	DATE
DRAWN	JO	1/9/2025

PROPRIETARY AND CONFIDENTIAL
 THE INFORMATION CONTAINED IN THIS DRAWING IS THE SOLE PROPERTY OF **FIRST**. ANY REPRODUCTION IN PART OR AS A WHOLE WITHOUT THE WRITTEN PERMISSION OF **FIRST** IS PROHIBITED.

COMMENTS:
 REMOVE ALL BURRS AND SHARP EDGES.



TITLE:
Algae Inflation Jig Foot

SIZE	DWG. NO.	REV
C	GE-25422	

SCALE: 2:5 SHEET 1 OF 1

4

3

2

1