

TE-23004 CUBE SHELF ASSEMBLY

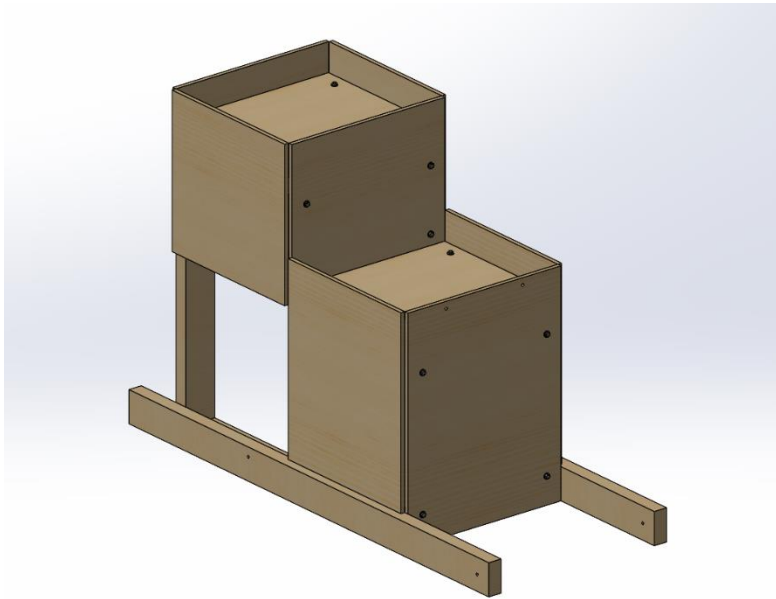

Description: This is a Cube Shelf, designed so that teams can practice without building a full GRID.

FILES INCLUDED

In this compressed folder, you will find all of the drawings, CAD Files and STEP Files for this design.

Drawings: For your convenience, all drawing files have been exported to PDF Format. Each major field assembly will have both assembly drawings and component drawings.

CAD Files: All SOLIDWORKS files required to build or modify the assembly.

STEP files: STEP files of the assembly are included for the convenience of non-SOLIDWORKS users.

SHOPPING LIST

Plywood and Lumber (Example Cut List is at end of Readme):

- 4' x 8' x 1/2" Thick Plywood – 1 Sheet
- 2" x 4" x 8' Lumber – 5 Pieces

Hardware:

- 1/4-20 x 2" Long – 20 Pieces
- 1/4-20 T-Nuts – 20 Pieces
- #8 Wood Screws x 1.5" long – Approximately 16 Pieces
- #8 Wood Screws x 3" Long – Approximately 32 Pieces

NOTE ON HARDWARE: All bolts and t-nuts can be replaced with approximately 20 more #8 x 1.5" wood screws. The design uses these t-nuts and bolts to allow itself to be broken down into a much smaller footprint for packing. If this is not a concern for your team, wood screws will make for a sturdier assembly. Below is an image showing how much space you can save using nuts and bolts instead of wood screws.

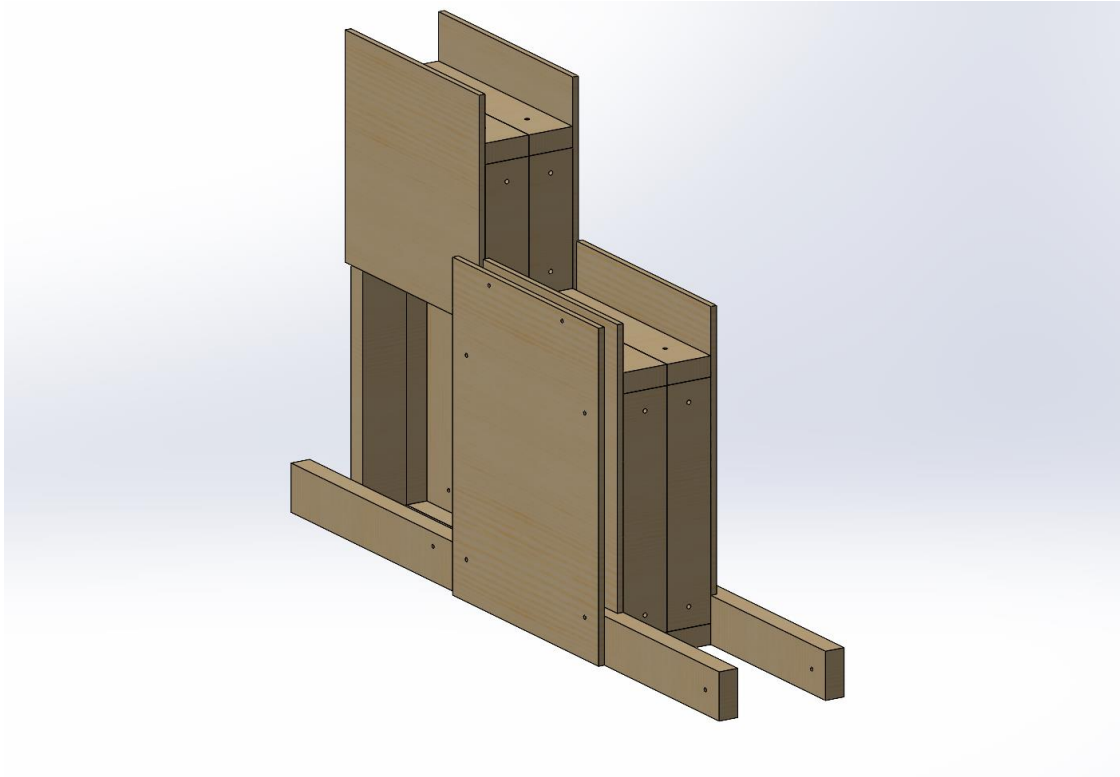

Using the t-nuts and bolts allows the Cube Shelf to be 10.5" wide instead of 21.5" wide

Notes about materials:

- Plywood and Hardboard Sheets – quality of plywood is up to the user. Plywood of lower qualities may contain voids and may warp more than high quality plywood. All dimensions listed are “nominal”. For example, ½” plywood is typically 15/32”.
- Lumber - quality of lumber is up to the user. Please keep in mind that lumber of lower qualities may warp more than high quality lumber. All dimensions below are the “mill cut” dimensions. For example, 2” x 4” lumber is really 1½” x 3½”.

Example Cut List (All Units are Inches):

Repetition	Stock dimensions	Panel	Qty
1x	96 x 48	18.5 x 23.5 / TE-23026	1
		17 x 17 / TE-23025	2
		17 x 20 / TE-23024	2
		18.5 x 15 / TE-23028	2
		16.5 x 18 / TE-23027	2

Repetition	Stock length	Part length / Label	Qty	Waste
1x	96	33 / TE-23021	2	Material remnant 0.625
		29 / TE-23020	1	Cut 0.375

Repetition	Stock length	Part length / Label	Qty	Waste
1x	96	10.5 / TE-23022	1	Material remnant 4.875
		17 / TE-23023	2	Cut 0.625
		17 / TE-23019	1	
		29 / TE-23020	1	

Repetition	Stock length	Part length / Label	Qty	Waste
2x	96	34.5 / TE-23018	1	Material remnant 7
		54.25 / TE-23005	1	Cut 0.25

Repetition	Stock length	Part length / Label	Qty	Waste
1x	96	10.5 / TE-23022	1	Material remnant 68.25
		17 / TE-23019	1	Cut 0.25