

TE-23001 END GRID ASSEMBLY

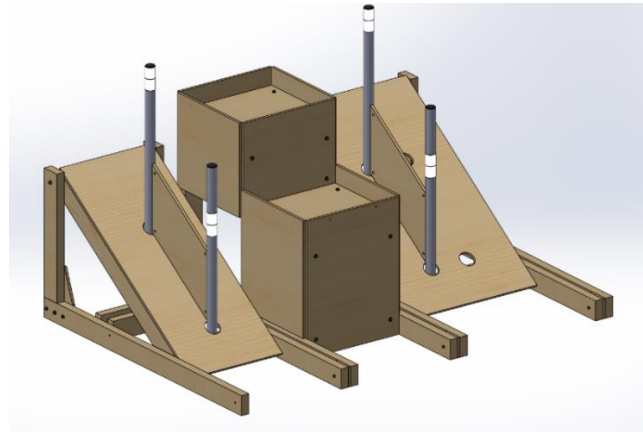

Description: This is one GRID, designed so that teams can practice with as close to a real set of GRIDs as possible, without needing to build the entire set of GRIDs. This Grid includes a Middle Cone Ramp, a Cube Shelf, and an End Cone Ramp that can be quickly adjusted to be a left or a right end. This can be made into a co-op GRID by replacing the End Cone Ramp with a Middle Cone Ramp. For details on using AprilTags with this assembly, see the AprilTag Images and User Guide document on the Playing Field page.

FILES INCLUDED

In this compressed folder, you will find all of the drawings, CAD Files and STEP Files for this design.

Drawings: For your convenience, all drawing files have been exported to PDF Format. Each major field assembly will have both assembly drawings and component drawings.

CAD Files: All SOLIDWORKS files required to build or modify the assembly.

STEP files: STEP files of the assembly are included for the convenience of non-SOLIDWORKS users.

SHOPPING LIST

Plywood and Lumber (Example Cut List is at end of Readme):

- 4' x 8' x 1/2" Thick Plywood – 1.5 Sheets
- 2" x 4" x 8' Lumber – 12 Pieces

Hardware:

- 1/4-20 x 2" Long – 20 Pieces
- 1/4-20 x 2.5" Long – 12 Pieces
- 1/4-20 x 3.5" Long – 4 Pieces
- 1/4-20 x 4" Long – 6 Pieces
- 1/4-20 x 5" Long – 8 Pieces
- 1/4-20 Wing Nuts – 28 Pieces
- 1/4-20 T-Nuts – 20 Pieces
- #8 Wood Screws x 1.5" long – Approximately 48 Pieces
- #8 Wood Screws x 3" Long – Approximately 64 Pieces

NOTE ON HARDWARE: All nuts, bolts and t-nuts except for the 5" long bolts and 8 of the wing nuts (holding the poles) can be replaced with approximately 12x #8 x 1.5" wood screws and 24x #8 x 3" wood screws. The design uses these nuts and bolts to allow itself to be broken down into a much smaller footprint for packing. If this is not a concern for your team, wood screws will make for a sturdier assembly. Below is an image showing how much space you can save using nuts and bolts instead of wood screws.

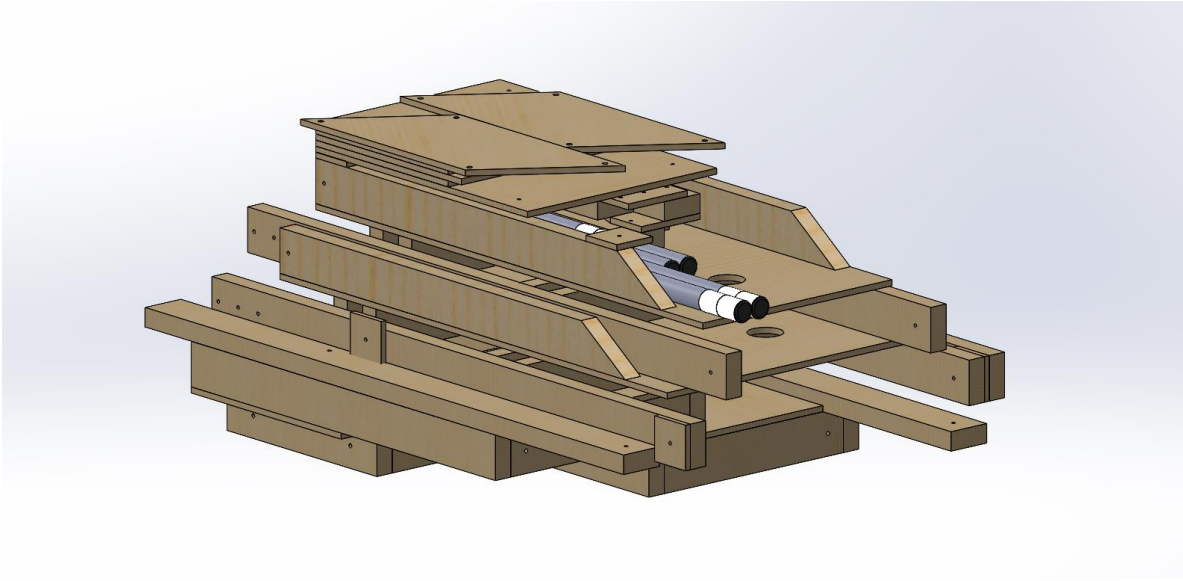

A GRID can be condensed to almost 1/4 of its usual size when assembled with nuts and bolts

Other:

- 2x 1-1/4" Schedule 40 Aluminum Pipe x 45 11/16" Long – This pipe could be made from Black Iron Pipe from the 2022 Team Element Hangar, or out of PVC if you don't have the resources to cut and drill metal pipes. AndyMark also sells this pipe (without the drilled holes) with a cap installed, part number **am-4942_back**.
- 2x 1-1/4" Schedule 40 Aluminum Pipe x 33 11/16" Long – This pipe could be made from Black Iron Pipe from the 2022 Team Element Hangar, or also out of PVC if you don't have the resources to cut and drill metal pipes. AndyMark also sells this pipe (without the drilled holes) with a cap installed, part number **am-4942_front**.
- AndyMark also sells these as a pair of poles, part number **am-4942_pair**, and a half field's worth of poles, part number **am-4942_half**. All AndyMark poles do not have the drilled holes in the sides of the poles.
- 4x Pole Caps. The official Pole Caps are **CCF-RT-13-1** from caplugs.com. These caps are also available at AndyMark individually, part number **am-1686**. There is also a CAD file of a similar but not exact model of the caps available, TE-23029, to be 3D printed or otherwise manufactured. If making this cap is a challenge, lengthening your pole by 3/16" and not having a cap is a relatively close alternative to the pole with the cap installed.
- 8x 5.25" long pieces of vision tape, supplied in the Kit of Parts.
- 2-3/4" Spade Bit, Forstner Bit or Hole Saw

Notes about materials:

- Plywood and Hardboard Sheets – quality of plywood is up to the user. Plywood of lower qualities may contain voids and may warp more than high quality plywood. All dimensions listed are "nominal". For example, 1/2" plywood is typically 15/32".
- Lumber - quality of lumber is up to the user. Please keep in mind that lumber of lower qualities may warp more than high quality lumber. All dimensions below are the "mill cut" dimensions. For example, 2" x 4" lumber is really 1 1/2" x 3 1/2".

Example Cut Sheets (All Units are Inches):

Repetition 1x	Stock dimensions 96 x 48	Panel	Qty
		15 x 18.5 / TE-23028	1
		5.75 x 9.5 / TE-23012	1
		43.875 x 18.5 / TE-23015	1
		18.5 x 23.5 / TE-23026	1
		17 x 20 / TE-23024	2
		16.5 x 18 / TE-23027	2
		43.875 x 25.75 / TE-23014	1
		25.52 x 9.75 / TE-23007	1
		3.5 x 3.5 / TE-23006	6

Repetition 1x	Stock dimensions 96 x 48	Panel	Qty
		17 x 17 / TE-23025	2
		15 x 18.5 / TE-23028	1
		9.75 x 25.52 / TE-23007	1
		9.5 x 5.75 / TE-23012	3

Repetition 1x	Stock length 96	Part length / Label	Qty	Waste
		39.125 / TE-23013	1	Material remnant 0
		29 / TE-23020	1	Cut 0.375
		10.5 / TE-23022	1	
		17 / TE-23023	1	

Repetition 4x	Stock length 96	Part length / Label	Qty	Waste
		54.25 / TE-23008	1	Material remnant 0.375
		18.5 / TE-23010	1	Cut 0.375
		22.5 / TE-23011	1	

Repetition 1x	Stock length 96	Part length / Label		Qty	Waste	
		29 / TE-23020		1	Material remnant	0.625
		33 / TE-23021		2	Cut	0.375
29 / TE-23020		33 / TE-23021		33 / TE-23021		

Repetition 1x	Stock length 96	Part length / Label		Qty	Waste	
		25.75 / TE-23009		1	Material remnant	0.875
		34.5 / TE-23018		2	Cut	0.375
25.75 / TE-23009		34.5 / TE-23018		34.5 / TE-23018		

Repetition 1x	Stock length 96	Part length / Label		Qty	Waste	
		25.75 / TE-23009		3	Material remnant	1.25
		17 / TE-23019		1	Cut	0.5
25.75 / TE-23009		25.75 / TE-23009		25.75 / TE-23009		17 / TE-23019

Repetition 3x	Stock length 96	Part length / Label		Qty	Waste	
		54.25 / TE-23005		1	Material remnant	2.375
		39.125 / TE-23013		1	Cut	0.25
54.25 / TE-23005		39.125 / TE-23013				

Repetition 1x	Stock length 96	Part length / Label		Qty	Waste	
		17 / TE-23019		1	Material remnant	51.125
		10.5 / TE-23022		1	Cut	0.375
17 / TE-23019		10.5 / TE-23022		17 / TE-23023		