

4

3

2

1

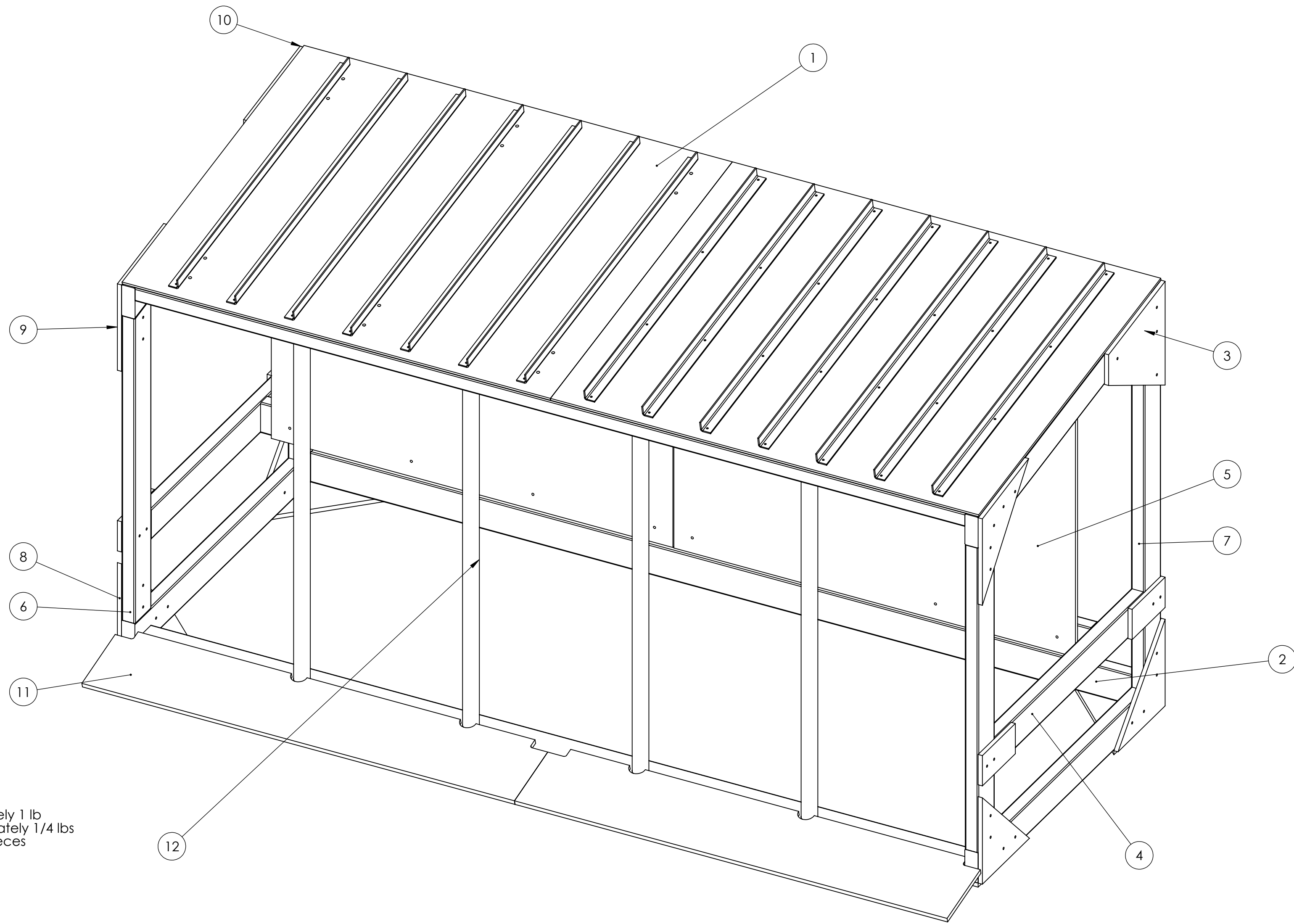

Note:
 #8 Wood Screws x 1.5" long approximately 1 lb
 #8 Wood Screws X 2.5" Long - Approximately 1/4 lbs
 1/4-20 x 2.5" Long Hex Head Bolts - 56 pieces
 1/4-20 Wing Nuts - 56 Pieces
 1/4" flat Washer - 56 pieces

12

4

ITEM NO.	PART NUMBER	DESCRIPTION	
1	TE-22417	Chute Assembly, Terminal	2
2	TE-22415	Base Frame, PF Terminal	1
3	TE-22416	Support Frame Long, PF Terminal	1
4	TE-22414	Support Frame, PF Terminal	1
5	TE-22406	Divider, PF Terminal	2
6	TE-22407	Short Leg, PF Terminal	2
7	TE-22408	Long Leg, PF Terminal	2
8	TE-22409	Gusset 1, PF Terminal	4
9	TE-22410	Gusset 2, PF Terminal	2
10	TE-22411	Gusset 3, PF Terminal	2
11	TE-22412	Ramp, PF Terminal	2
12	TE-22413	Pipe, PF Terminal	4

UNLESS OTHERWISE SPECIFIED:

DIMENSIONS ARE IN INCHES
 TOLERANCES:
 FRACTIONAL $\pm 1/16$
 ANGULAR: MACH $\pm 1^\circ$ BEND $\pm 1^\circ$
 TWO PLACE DECIMAL $\pm .13$
 THREE PLACE DECIMAL $\pm .125$

MATERIAL/FINISH:

DO NOT SCALE DRAWING

TEAM	NAME	DATE
DRAWN	MS	1/3/2022

PROPRIETARY AND CONFIDENTIAL

THE INFORMATION CONTAINED IN THIS DRAWING IS THE SOLE PROPERTY OF **FIRST**. ANY REPRODUCTION IN PART OR AS A WHOLE WITHOUT THE WRITTEN PERMISSION OF **FIRST** IS PROHIBITED.

COMMENTS:

REMOVE ALL BURRS AND SHARP EDGES.



TITLE:
Terminal Complex Assembly

SIZE	DWG. NO.	REV
------	----------	-----

C	TE-22401	
----------	----------	--

SCALE: 1:16	SHEET 1 OF 3
-------------	--------------

4

3

2

1

4

3

2

1

D

D

C

C

B

B

A

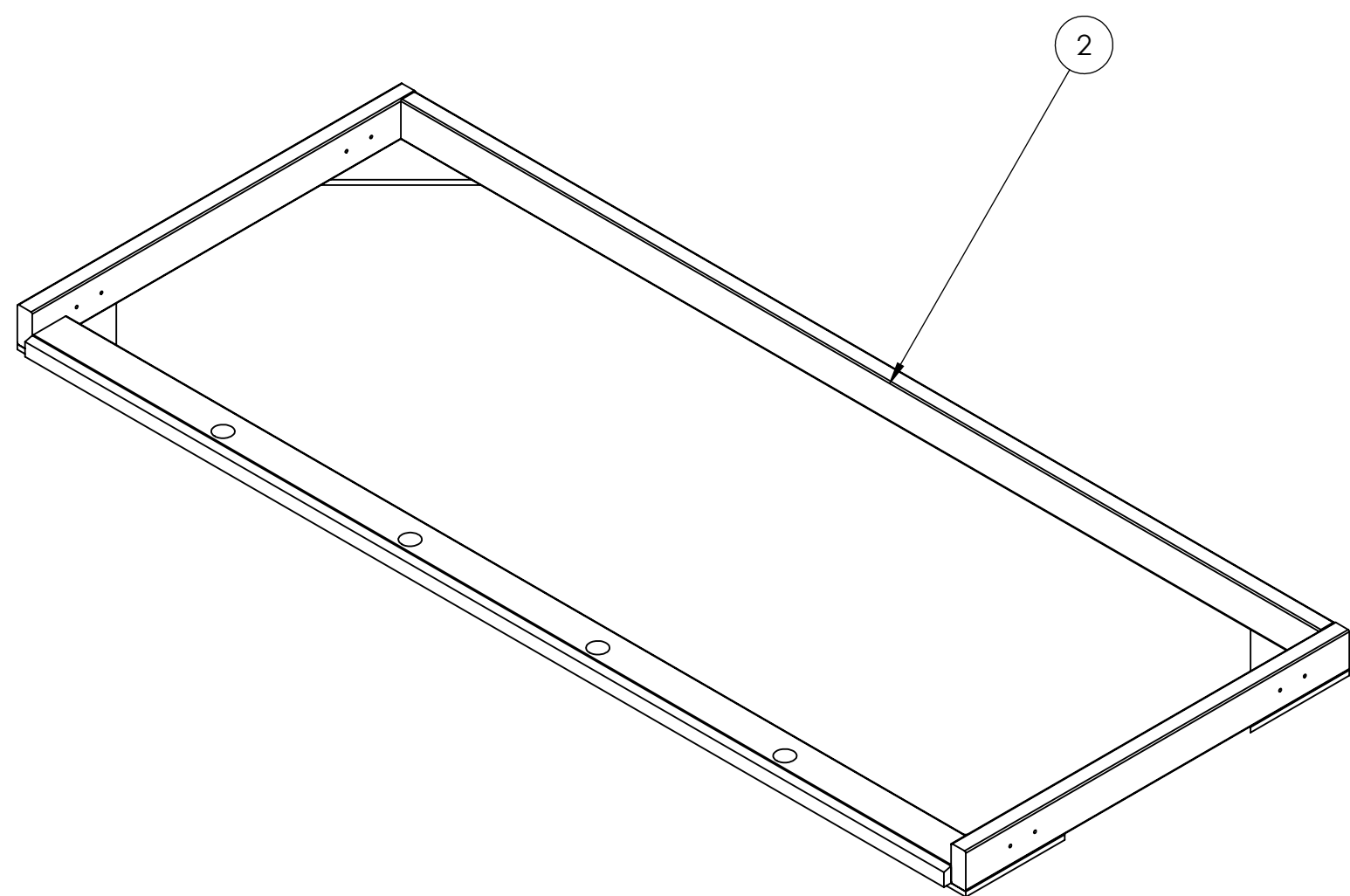

A

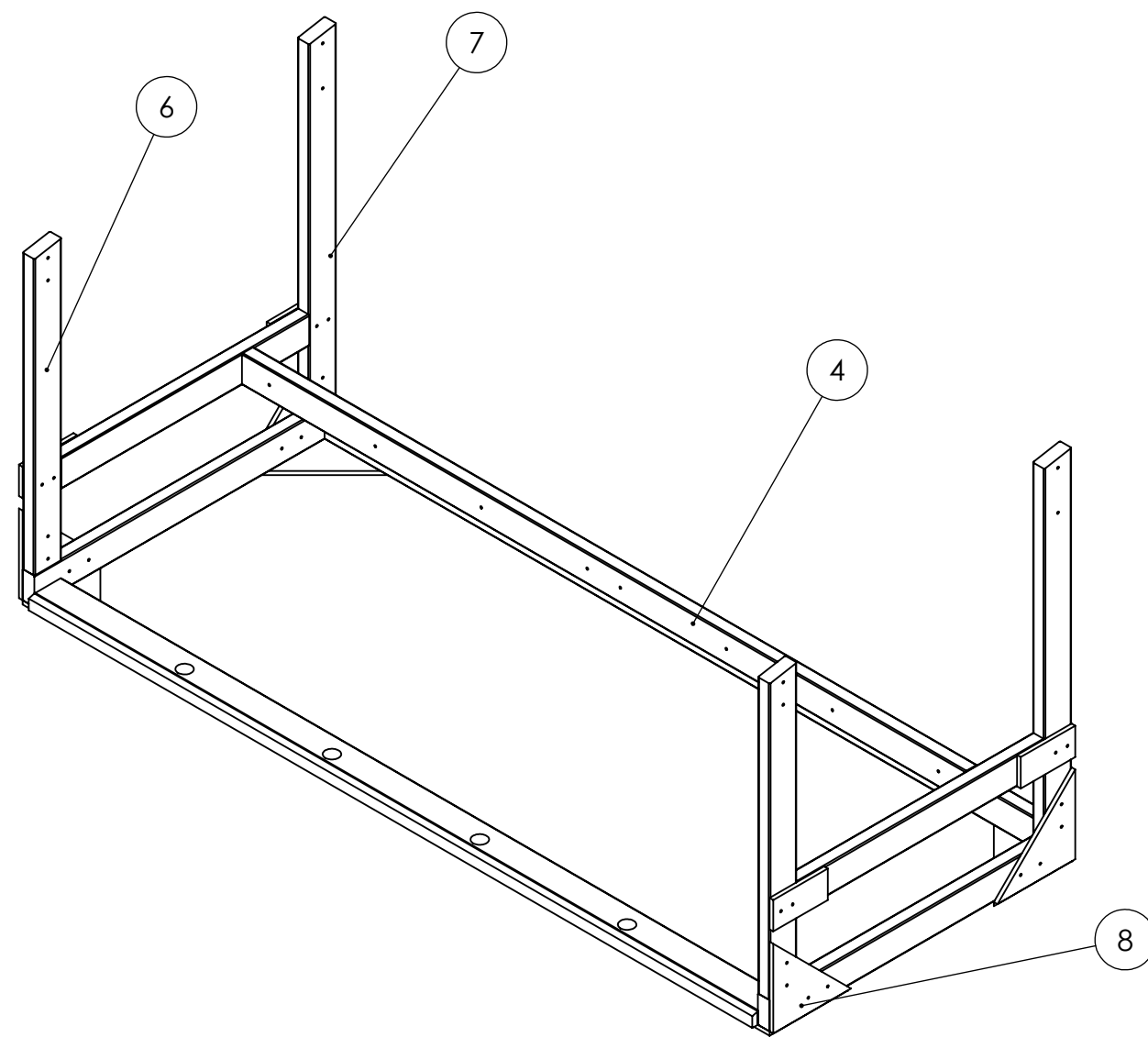

Place Item 2



Attach all items using bolts or screws

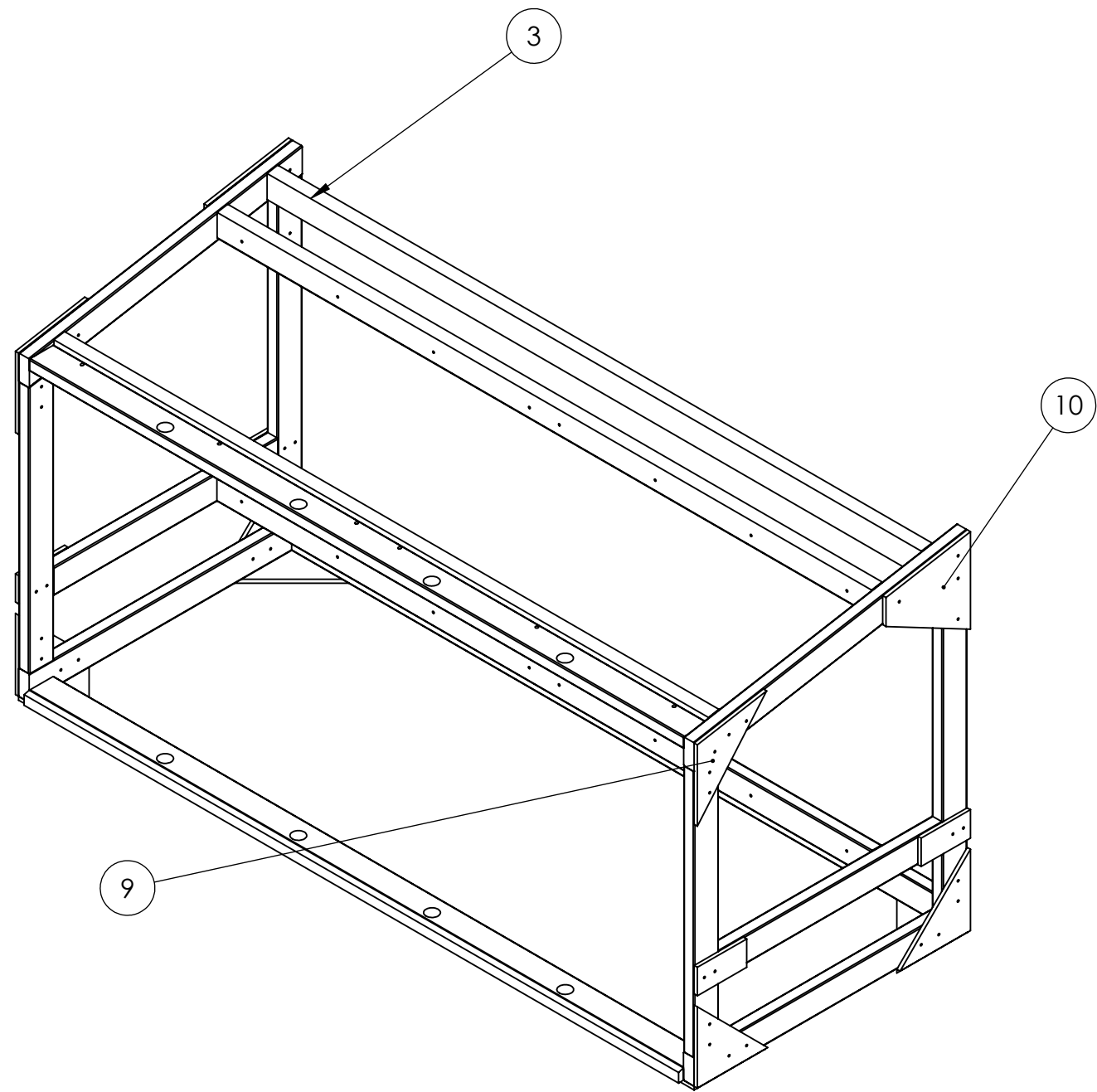

UNLESS OTHERWISE SPECIFIED: DIMENSIONS ARE IN INCHES TOLERANCES: FRACTIONAL ±1/16 ANGULAR: MACH ±1° BEND ±1° TWO PLACE DECIMAL ±.13 THREE PLACE DECIMAL ±.125 MATERIAL/FINISH: DO NOT SCALE DRAWING	TEAM	NAME	DATE	 
	DRAWN	MS	1/3/2022	
	PROPRIETARY AND CONFIDENTIAL			TITLE:
	THE INFORMATION CONTAINED IN THIS DRAWING IS THE SOLE PROPERTY OF FIRST® . ANY REPRODUCTION IN PART OR AS A WHOLE WITHOUT THE WRITTEN PERMISSION OF FIRST® IS PROHIBITED.			<h1>Terminal Complex Assembly</h1>
	COMMENTS: REMOVE ALL BURRS AND SHARP EDGES.			SIZE: DWG, 10.00 C TE-22401 REV:
	SCALE: 1:16		SHEET 2 OF 3	

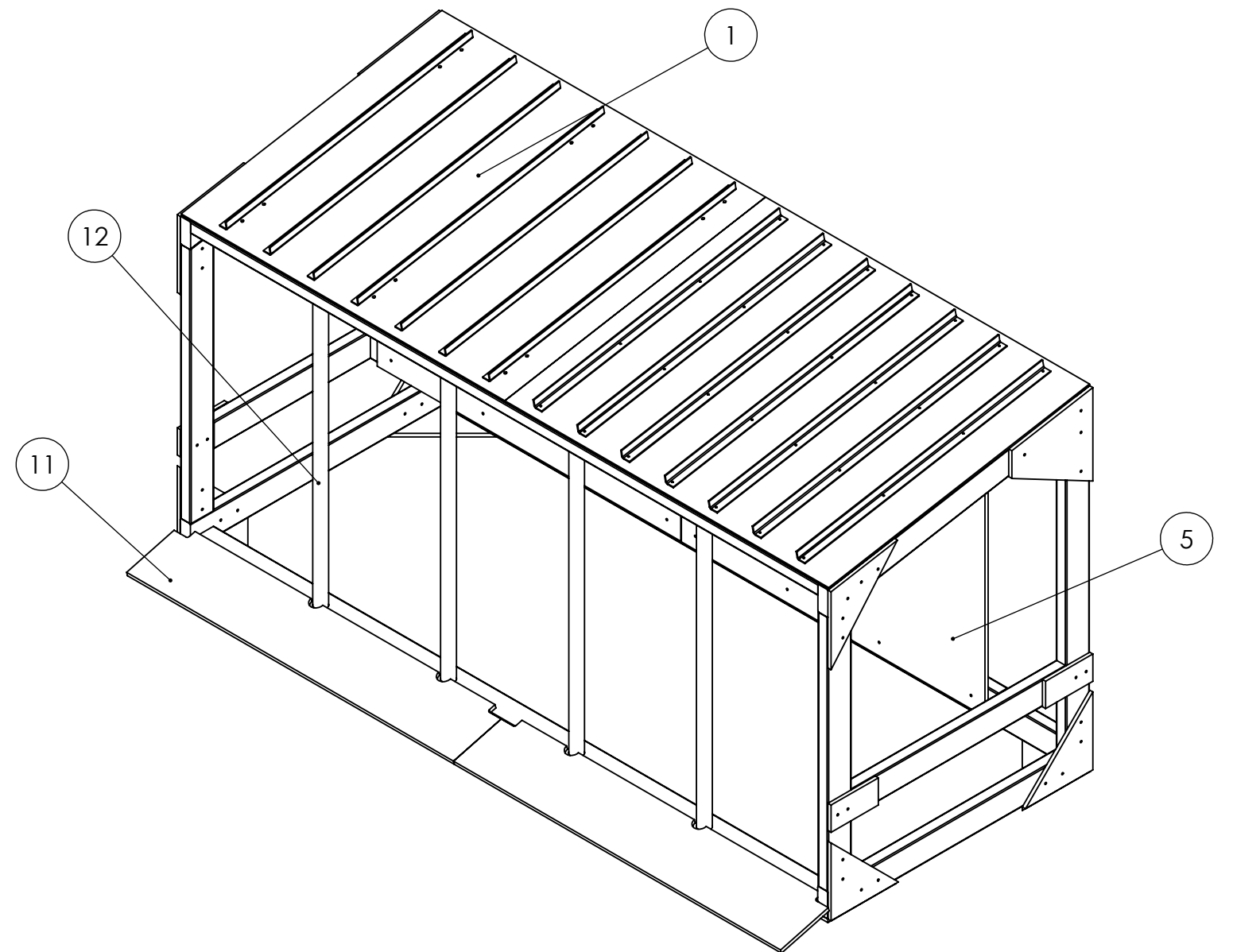

Attach all items using bolts or screws



- Notes:
1. place item 12 in the holes.
 2. Attach Item 5 using bolts.
 3. Place Items 1 and 11 using screws or cable ties.

UNLESS OTHERWISE SPECIFIED: DIMENSIONS ARE IN INCHES TOLERANCES: FRACTIONAL $\pm 1/16$ ANGULAR: MACH $\pm 1^\circ$ BEND $\pm 1^\circ$ TWO PLACE DECIMAL $\pm .13$ THREE PLACE DECIMAL $\pm .125$ MATERIAL/FINISH: DO NOT SCALE DRAWING	TEAM	NAME	DATE	 
	DRAWN	MS	1/3/2022	
PROPRIETARY AND CONFIDENTIAL		TITLE:		
THE INFORMATION CONTAINED IN THIS DRAWING IS THE SOLE PROPERTY OF FIRST . ANY REPRODUCTION IN PART OR AS A WHOLE WITHOUT THE WRITTEN PERMISSION OF FIRST IS PROHIBITED.		<h1>Terminal Complex Assembly</h1>		
COMMENTS: REMOVE ALL BURRS AND SHARP EDGES.		SIZE	DWG. NO.	REV
		<h2>C TE-22401</h2>		
		SCALE: 1:16		SHEET 3 OF 3

4

3

2

1

D

D

C

C



B

B

A

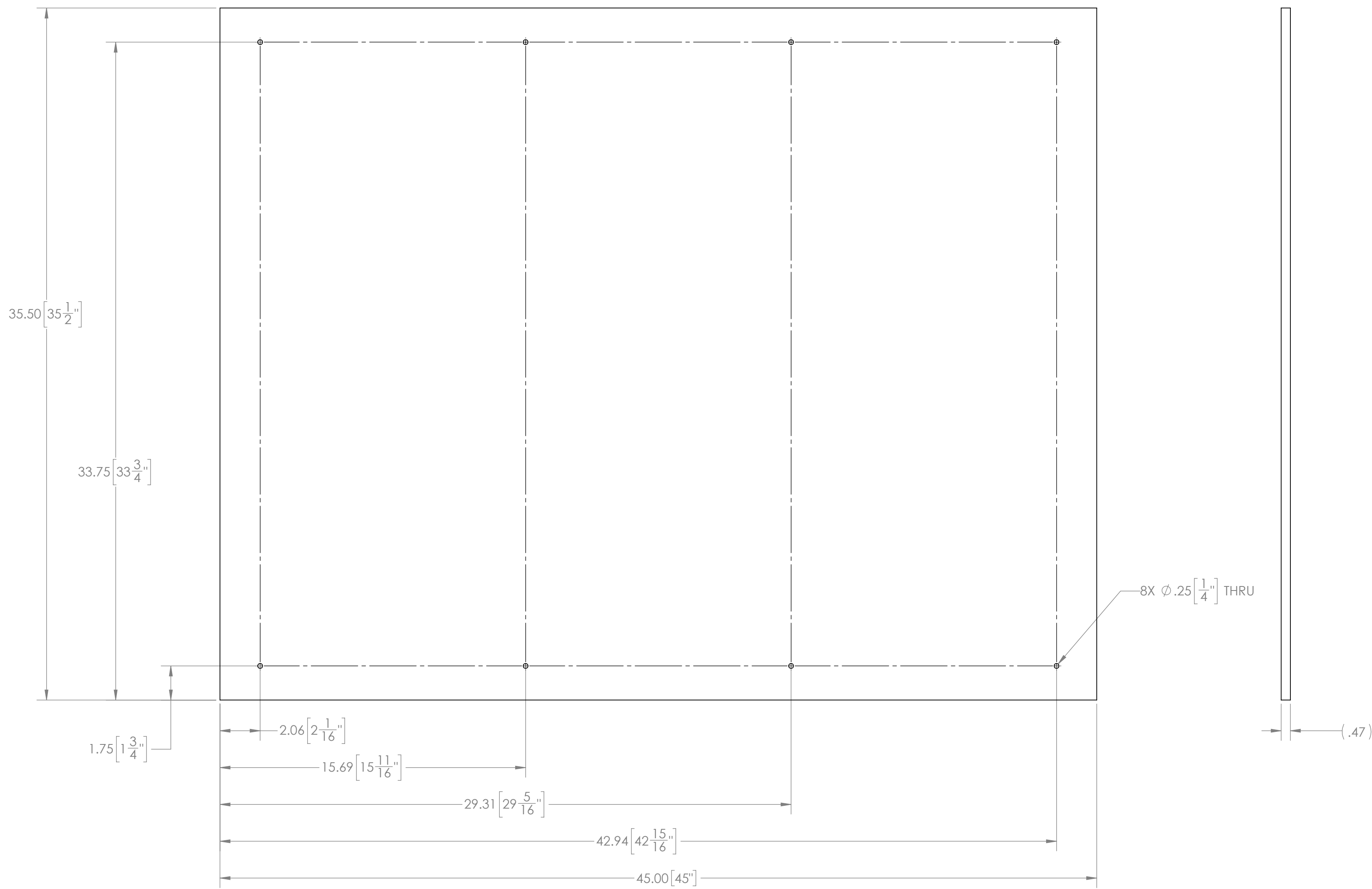
A



UNLESS OTHERWISE SPECIFIED: DIMENSIONS ARE IN INCHES TOLERANCES: FRACTIONAL ± 1/16 ANGULAR: MACH ± 1° BEND ± 1° TWO PLACE DECIMAL ± .13 THREE PLACE DECIMAL ± .125	TEAM	NAME	DATE	 						
	DRAWN	DF	11/8/2021							
MATERIAL/FINISH: 1/2" Plywood	PROPRIETARY AND CONFIDENTIAL THE INFORMATION CONTAINED IN THIS DRAWING IS THE SOLE PROPERTY OF FIRST® . ANY REPRODUCTION IN PART OR AS A WHOLE WITHOUT THE WRITTEN PERMISSION OF FIRST® IS PROHIBITED.			TITLE: Divider, PF Terminal						
DO NOT SCALE DRAWING	COMMENTS: REMOVE ALL BURRS AND SHARP EDGES.			<table border="1"> <tr> <td>SIZE</td> <td>DWG. NO.</td> <td>REV</td> </tr> <tr> <td>C</td> <td>TE-22406</td> <td></td> </tr> </table>	SIZE	DWG. NO.	REV	C	TE-22406	
	SIZE	DWG. NO.	REV							
C	TE-22406									
SCALE: 1:4			SHEET 1 OF 1							

4

3

2

1

D

D

C

C

B

B

A

A

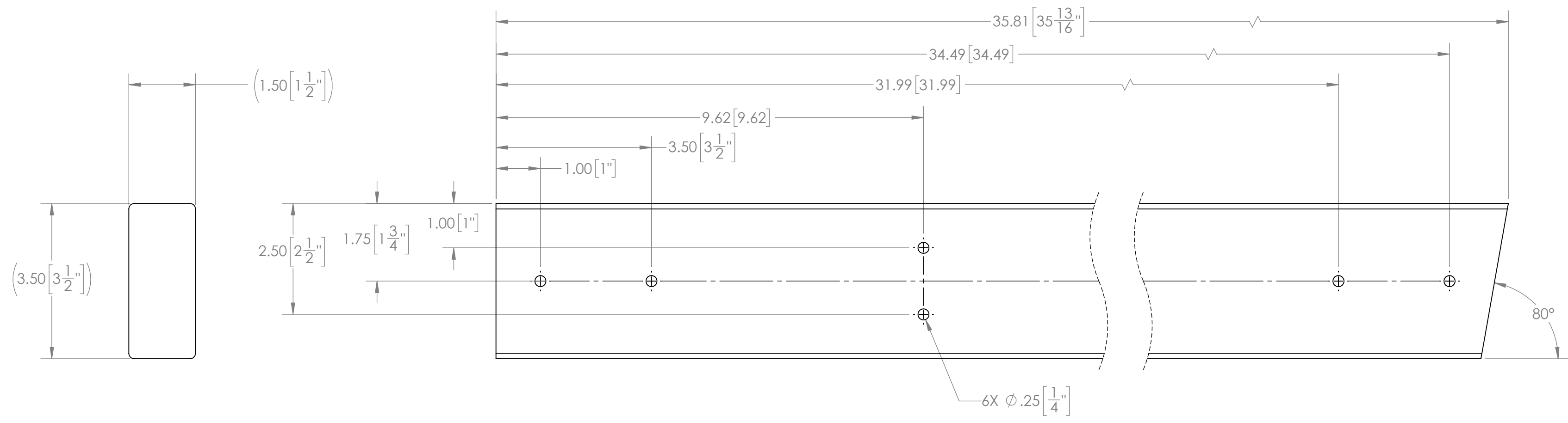

UNLESS OTHERWISE SPECIFIED: DIMENSIONS ARE IN INCHES TOLERANCES: FRACTIONAL ± 1/16 ANGULAR: MACH ± 1° BEND ± 1° TWO PLACE DECIMAL ± .13 THREE PLACE DECIMAL ± .125 MATERIAL/FINISH: 2 x 4 Pine Lumber DO NOT SCALE DRAWING	TEAM	NAME	DATE	
	DRAWN	DF	11/2/2021	
PROPRIETARY AND CONFIDENTIAL THE INFORMATION CONTAINED IN THIS DRAWING IS THE SOLE PROPERTY OF FIRST® . ANY REPRODUCTION IN PART OR AS A WHOLE WITHOUT THE WRITTEN PERMISSION OF FIRST® IS PROHIBITED.				TITLE:
				Short Leg, PF Terminal
COMMENTS: REMOVE ALL BURRS AND SHARP EDGES.		SIZE	DWG. NO.	REV
		C	TE-22407	
		SCALE: 1:2	SHEET 1 OF 1	

4

3

2

1

4

3

2

1

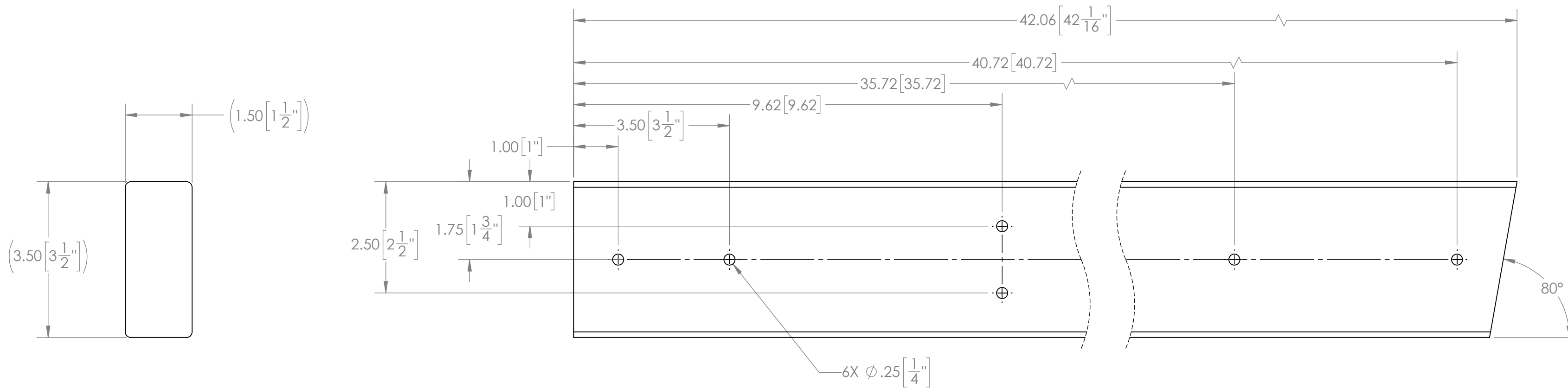

UNLESS OTHERWISE SPECIFIED:

DIMENSIONS ARE IN INCHES
 TOLERANCES:
 FRACTIONAL ± 1/16
 ANGULAR: MACH ± 1° BEND ± 1°
 TWO PLACE DECIMAL ± .13
 THREE PLACE DECIMAL ± .125

MATERIAL/FINISH:
 2 x 4 Pine Lumber

DO NOT SCALE DRAWING

TEAM	NAME	DATE
DRAWN	DF	11/2/2021

PROPRIETARY AND CONFIDENTIAL

THE INFORMATION CONTAINED IN THIS DRAWING IS THE SOLE PROPERTY OF **FIRST®**. ANY REPRODUCTION IN PART OR AS A WHOLE WITHOUT THE WRITTEN PERMISSION OF **FIRST®** IS PROHIBITED.

COMMENTS:
 REMOVE ALL BURRS AND SHARP EDGES.



TITLE:
**Long Leg TE,
 Terminal**

SIZE	DWG. NO.	REV
C	TE-22408	

SCALE: 1:2 SHEET 1 OF 1

4

3

2

1

D

D

C

C

B

B

A

A

4

3

2

1

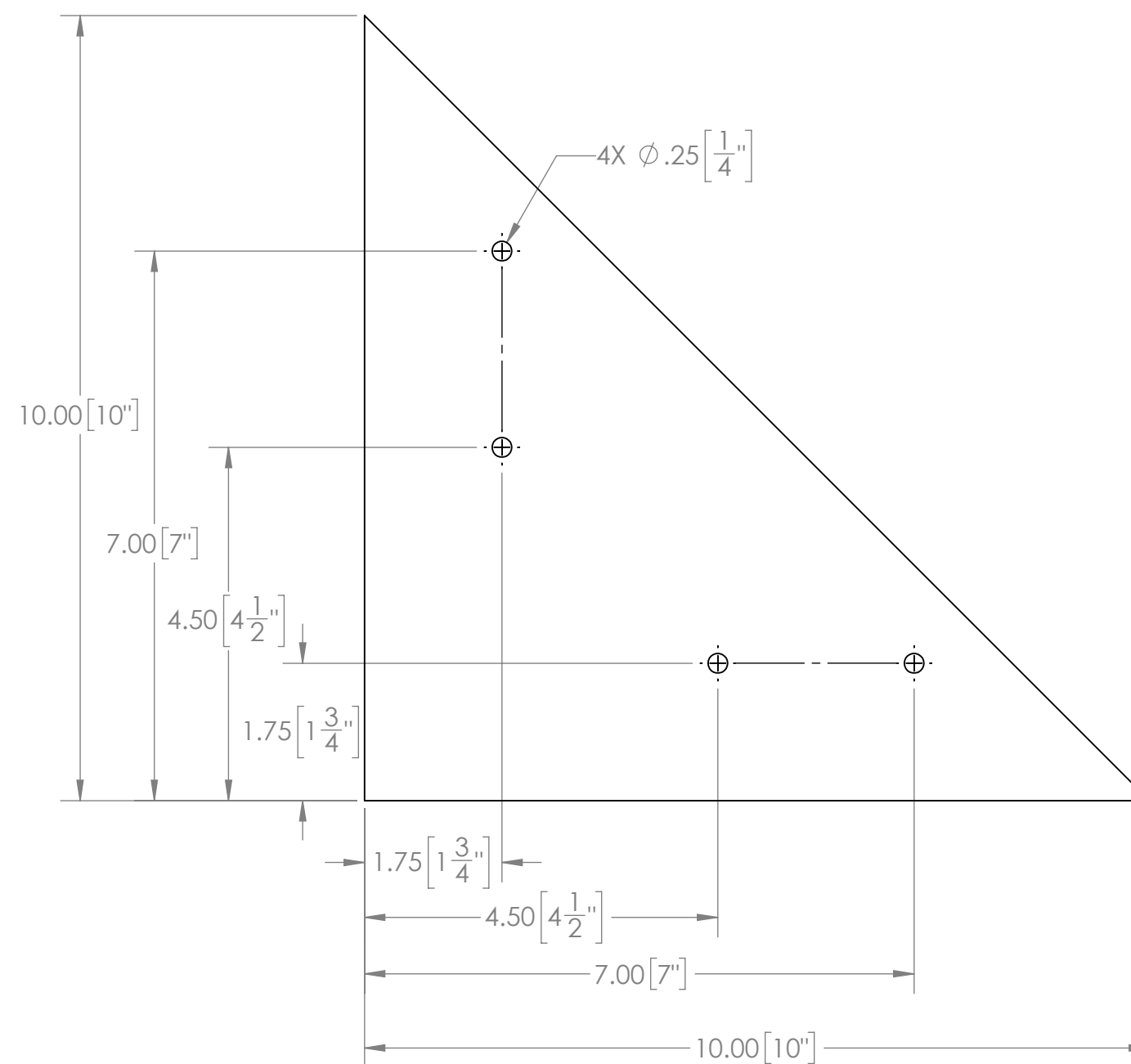
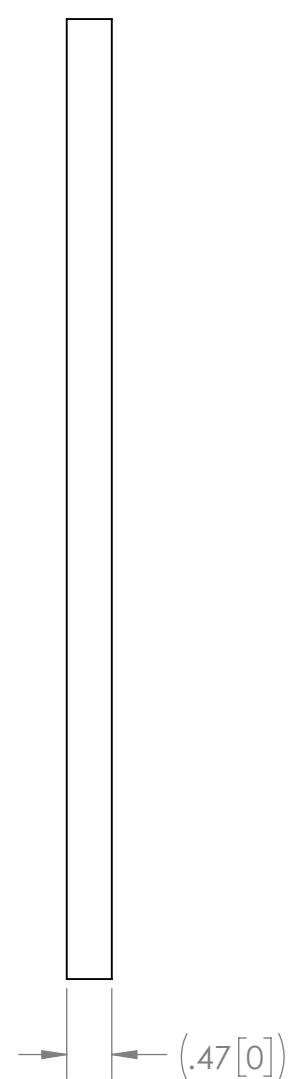

UNLESS OTHERWISE SPECIFIED:

DIMENSIONS ARE IN INCHES
 TOLERANCES:
 FRACTIONAL $\pm 1/16$
 ANGULAR: MACH $\pm 1^\circ$ BEND $\pm 1^\circ$
 TWO PLACE DECIMAL $\pm .13$
 THREE PLACE DECIMAL $\pm .125$

MATERIAL/FINISH:
 1/2" Plywood

DO NOT SCALE DRAWING

TEAM	NAME	DATE
DRAWN	DF	11/2/2021

PROPRIETARY AND CONFIDENTIAL
 THE INFORMATION CONTAINED IN THIS DRAWING IS THE SOLE PROPERTY OF **FIRST**. ANY REPRODUCTION IN PART OR AS A WHOLE WITHOUT THE WRITTEN PERMISSION OF **FIRST** IS PROHIBITED.

COMMENTS:
 REMOVE ALL BURRS AND SHARP EDGES.



TITLE:
**Gusset 1 TE,
 Terminal**

SIZE	DWG. NO.	REV
C	TE-22409	

SCALE: 1:2 SHEET 1 OF 1

4

3

2

1

D

D

C

C

B

B

A

A

4

3

2

1

D

D

C

C



B

B

A

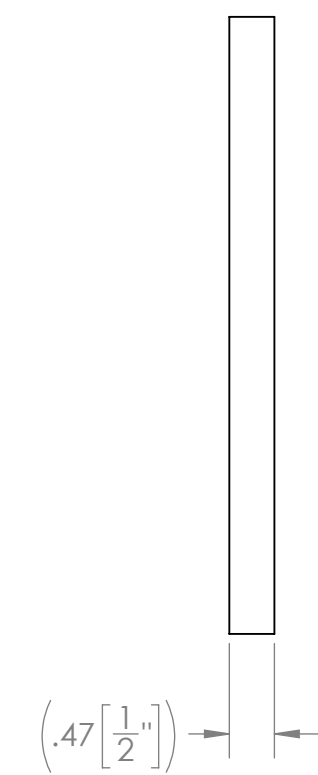
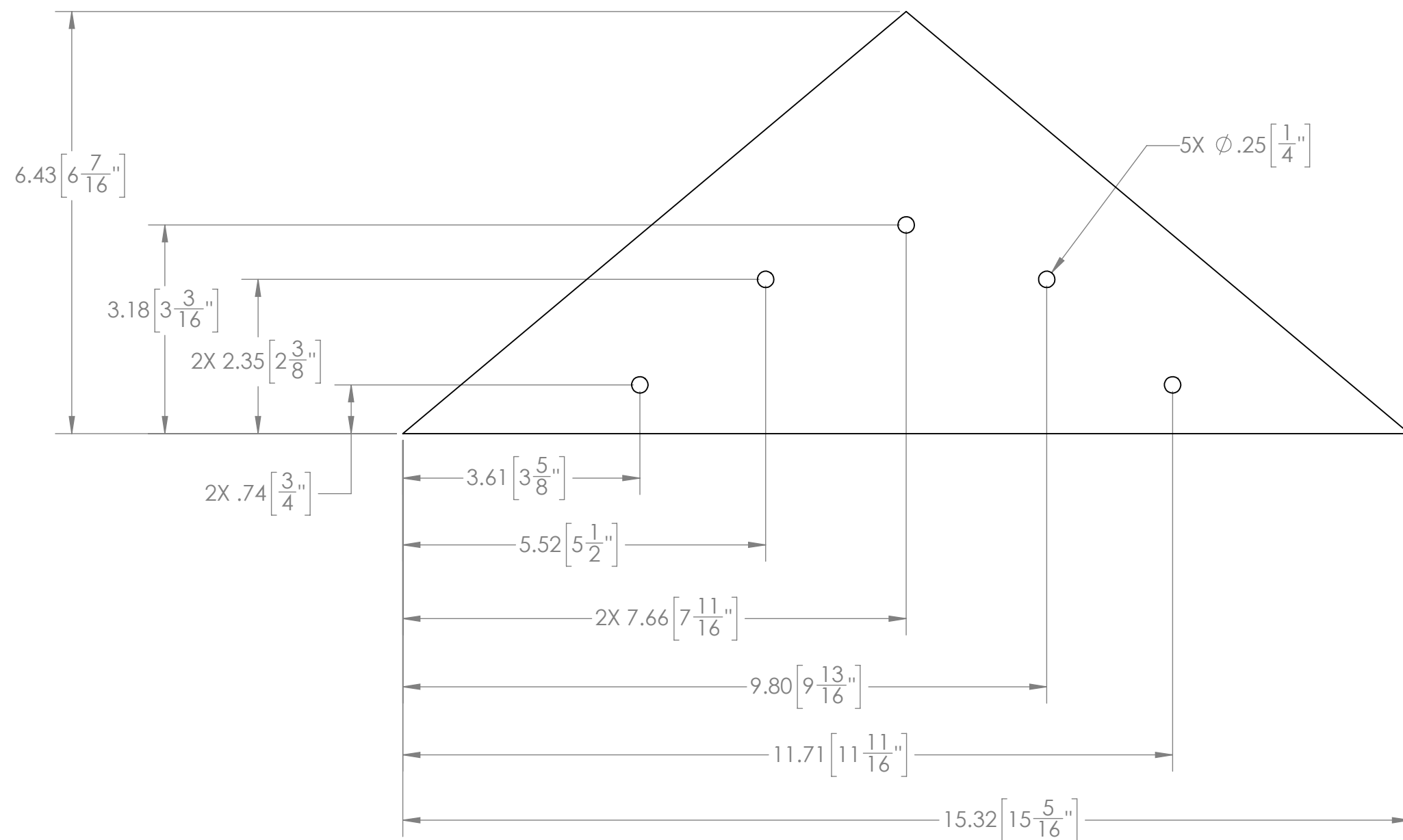
A



UNLESS OTHERWISE SPECIFIED: DIMENSIONS ARE IN INCHES TOLERANCES: FRACTIONAL ±1/16 ANGULAR: MACH ±1° BEND ±1° TWO PLACE DECIMAL ±.13 THREE PLACE DECIMAL ±.125 MATERIAL/FINISH: 1/2" Plywood DO NOT SCALE DRAWING	TEAM	NAME	DATE	 
	DRAWN	DF	11/2/2021	
	PROPRIETARY AND CONFIDENTIAL			TITLE: <h2 style="text-align: center;">Gusset 2 TE, Terminal</h2>
	THE INFORMATION CONTAINED IN THIS DRAWING IS THE SOLE PROPERTY OF FIRST® . ANY REPRODUCTION IN PART OR AS A WHOLE WITHOUT THE WRITTEN PERMISSION OF FIRST® IS PROHIBITED.			
	COMMENTS:			SIZE DWG. NO. REV C TE-22410
	REMOVE ALL BURRS AND SHARP EDGES.			SCALE: 1:2 SHEET 1 OF 1

4

3

2

1

4

3

2

1

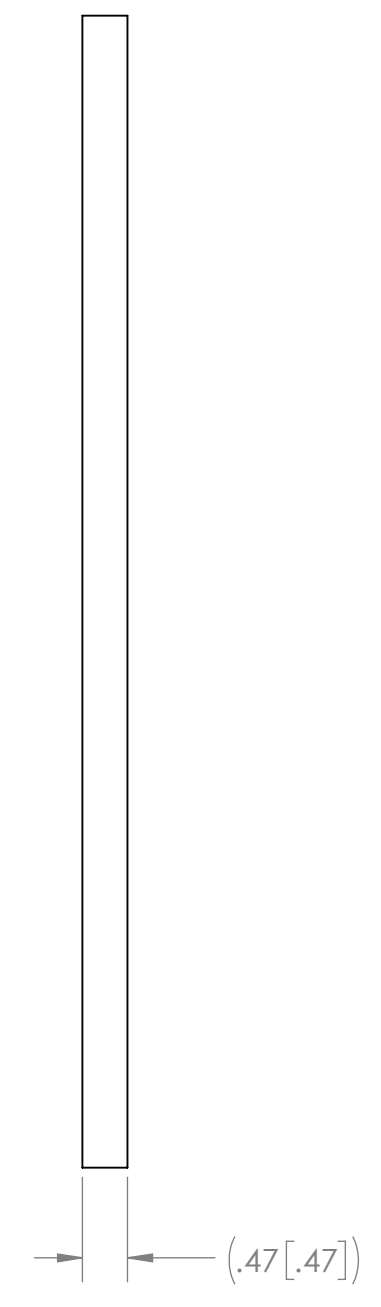
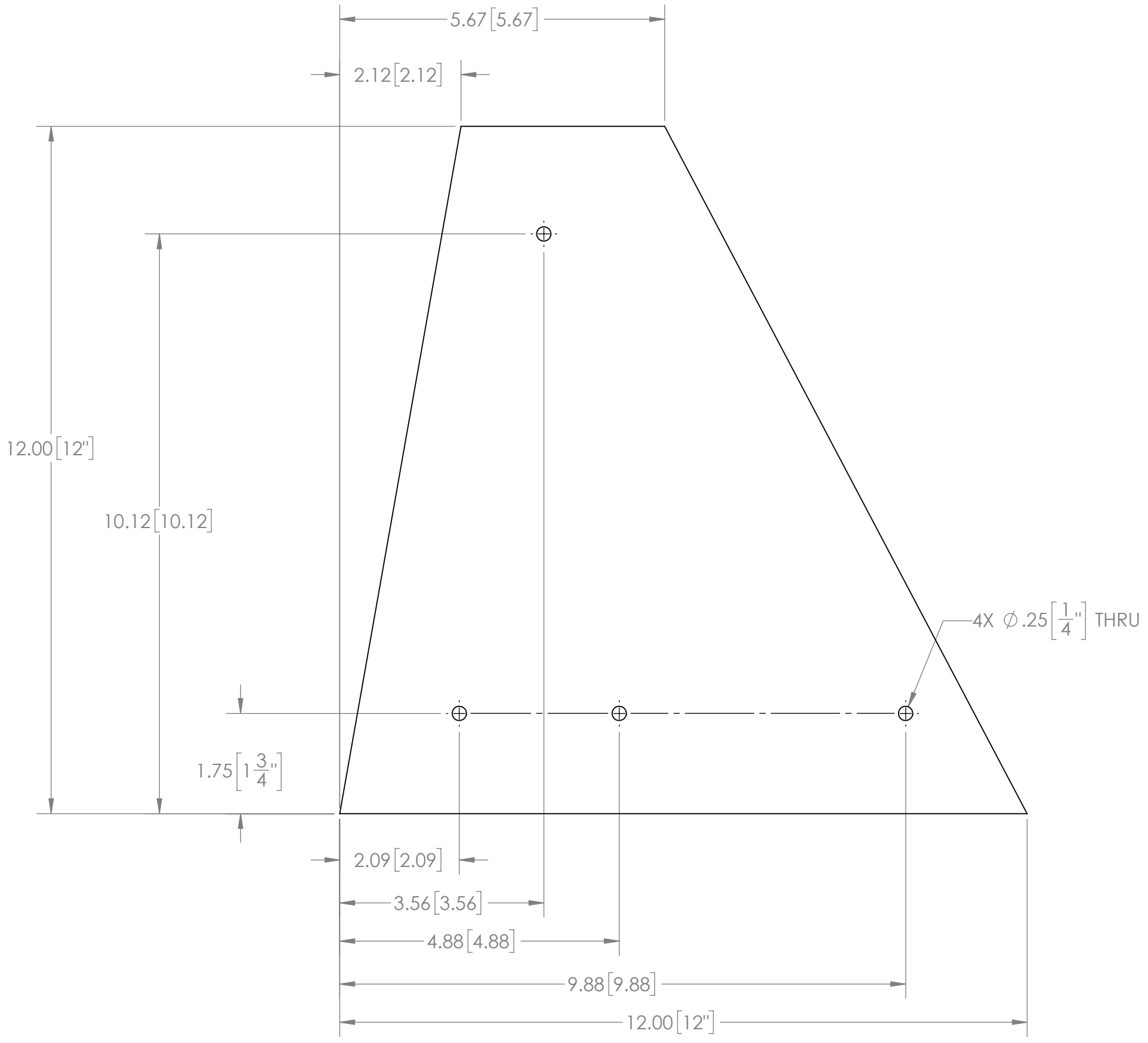

UNLESS OTHERWISE SPECIFIED: DIMENSIONS ARE IN INCHES TOLERANCES: FRACTIONAL ± 1/16 ANGULAR: MACH ± 1° BEND ± 1° TWO PLACE DECIMAL ± .13 THREE PLACE DECIMAL ± .125 MATERIAL/FINISH: 1/2" Plywood	TEAM	NAME	DATE	
	DRAWN	DF	11/8/2021	
DO NOT SCALE DRAWING	PROPRIETARY AND CONFIDENTIAL THE INFORMATION CONTAINED IN THIS DRAWING IS THE SOLE PROPERTY OF FIRST® . ANY REPRODUCTION IN PART OR AS A WHOLE WITHOUT THE WRITTEN PERMISSION OF FIRST® IS PROHIBITED.			TITLE:
	COMMENTS: REMOVE ALL BURRS AND SHARP EDGES.			Gusset 3 TE, Terminal
	SIZE	DWG. NO.	REV	
	C	TE-22411		
	SCALE: 1:2		SHEET 1 OF 1	

4

3

2

1

D

D

C

C

B

B

A

A



4

3

2

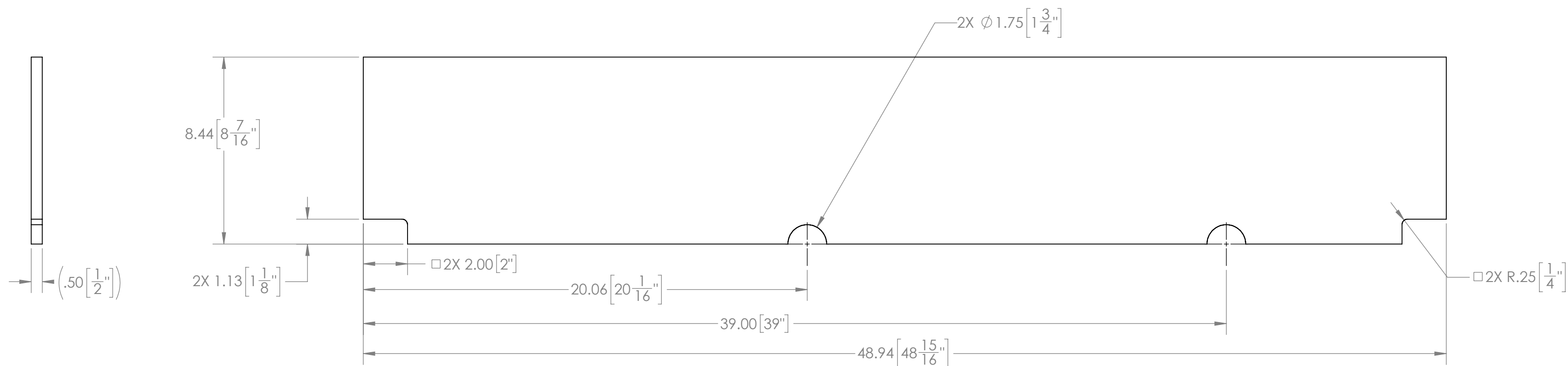
1



UNLESS OTHERWISE SPECIFIED: DIMENSIONS ARE IN INCHES TOLERANCES: FRACTIONAL $\pm 1/16$ ANGULAR: MACH $\pm 1^\circ$ BEND $\pm 1^\circ$ TWO PLACE DECIMAL $\pm .13$ THREE PLACE DECIMAL $\pm .125$ MATERIAL/FINISH: 1/2" Plywood DO NOT SCALE DRAWING	TEAM	NAME	DATE	 
	DRAWN	DF	11/8/2021	
	PROPRIETARY AND CONFIDENTIAL THE INFORMATION CONTAINED IN THIS DRAWING IS THE SOLE PROPERTY OF FIRST . ANY REPRODUCTION IN PART OR AS A WHOLE WITHOUT THE WRITTEN PERMISSION OF FIRST IS PROHIBITED.			TITLE:
	COMMENTS: REMOVE ALL BURRS AND SHARP EDGES.			Ramp TE, Terminal
SIZE		DWG. NO.	REV	
C		TE-22412		
SCALE: 1:4		SHEET 1 OF 1		

4

3

2

1

D

D

C

C

B

B

A

A

4



3

2

1

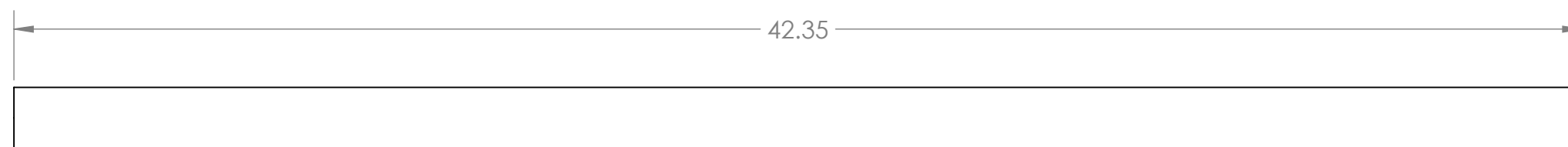
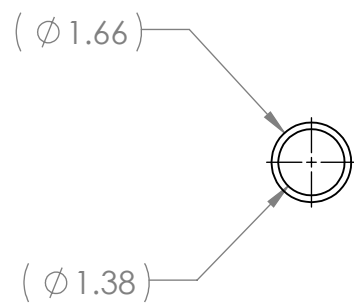
REVISIONS				
ZONE	REV.	DESCRIPTION	DATE	APPROVED
A2	A	Changed material	1/5/2022	DAF



UNLESS OTHERWISE SPECIFIED:	TEAM	NAME	DATE	 
	DRAWN	DF	11/8/2021	
DIMENSIONS ARE IN INCHES TOLERANCES: FRACTIONAL $\pm 1/16$ ANGULAR: MACH $\pm 1^\circ$ BEND $\pm 1^\circ$ TWO PLACE DECIMAL $\pm .13$ THREE PLACE DECIMAL $\pm .125$	PROPRIETARY AND CONFIDENTIAL			TITLE: <h2>Pipe, PF Terminal</h2>
	MATERIAL/FINISH: 1-1/4" Schedule 40 Black Iron Pipe 	THE INFORMATION CONTAINED IN THIS DRAWING IS THE SOLE PROPERTY OF FIRST . ANY REPRODUCTION IN PART OR AS A WHOLE WITHOUT THE WRITTEN PERMISSION OF FIRST IS PROHIBITED.		
DO NOT SCALE DRAWING	COMMENTS: REMOVE ALL BURRS AND SHARP EDGES.			SIZE: C DWG. NO.: TE-22413 SCALE: 1:8
				REV: A SHEET 1 OF 1

4

3

2

1

D

D

C

C

B

B

A

A

4

3

2

1

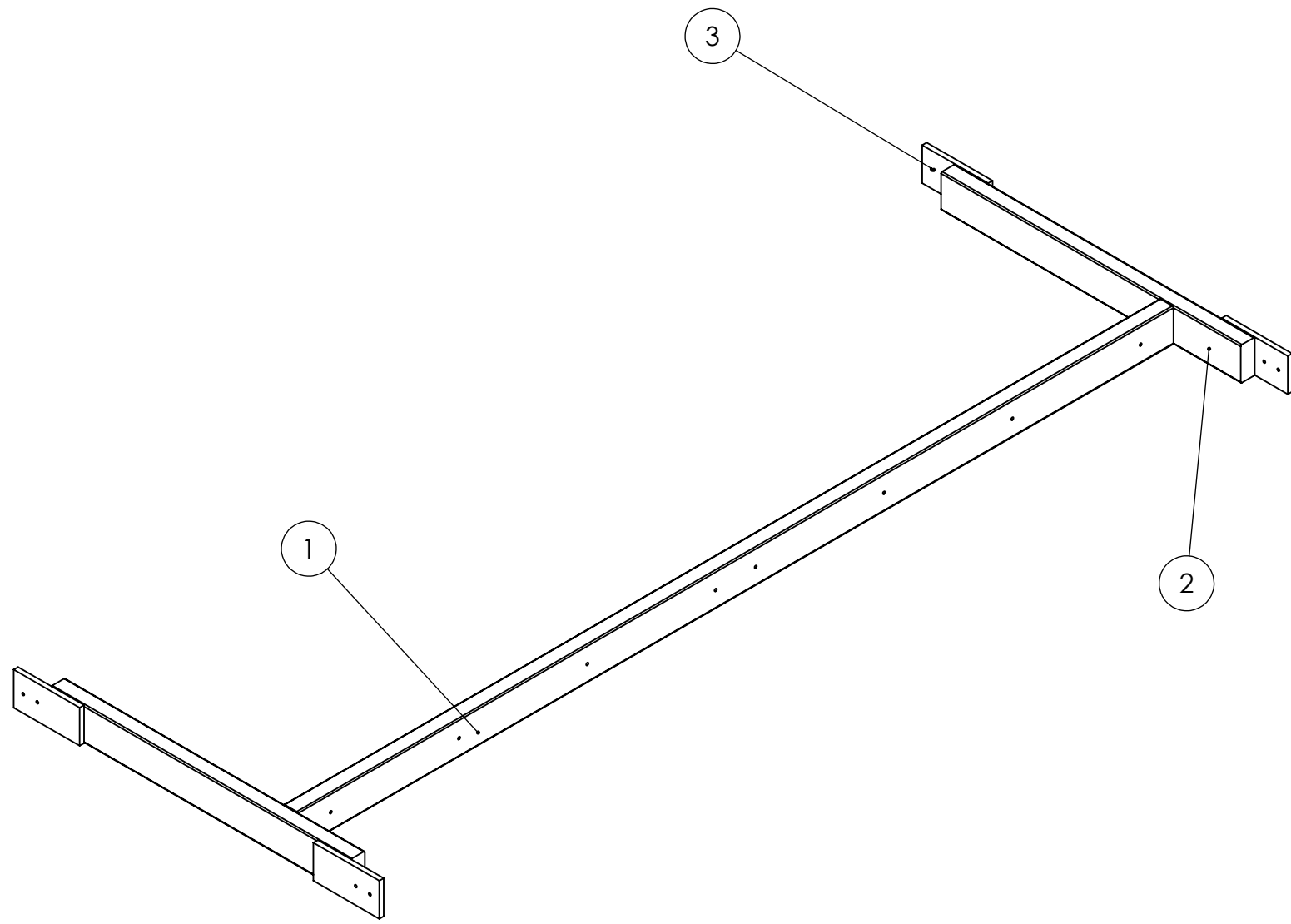

D

D

C

C

B

B

A

A

ITEM NO.	PART NUMBER	DESCRIPTION	QTY.
1	TE-22414-01	2 x 4 Pine Lumber	1
2	TE-22414-02	2 x 4 Pine Lumber	2
3	TE-22414-03	1/2" Plywood	4

UNLESS OTHERWISE SPECIFIED: DIMENSIONS ARE IN INCHES TOLERANCES: FRACTIONAL $\pm 1/16$ ANGULAR: MACH $\pm 1^\circ$ BEND $\pm 1^\circ$ TWO PLACE DECIMAL $\pm .13$ THREE PLACE DECIMAL $\pm .125$ MATERIAL/FINISH: DO NOT SCALE DRAWING	TEAM	NAME	DATE
	DRAWN	MS	1/3/2022
	PROPRIETARY AND CONFIDENTIAL		
	THE INFORMATION CONTAINED IN THIS DRAWING IS THE SOLE PROPERTY OF FIRST . ANY REPRODUCTION IN PART OR AS A WHOLE WITHOUT THE WRITTEN PERMISSION OF FIRST IS PROHIBITED.		
COMMENTS:			
REMOVE ALL BURRS AND SHARP EDGES.			



TITLE:		
Support Frame TE, Terminal		
SIZE	DWG. NO.	REV
C	TE-22414	
SCALE: 1:12		SHEET 1 OF 3

4

3

2

1

4

3

2

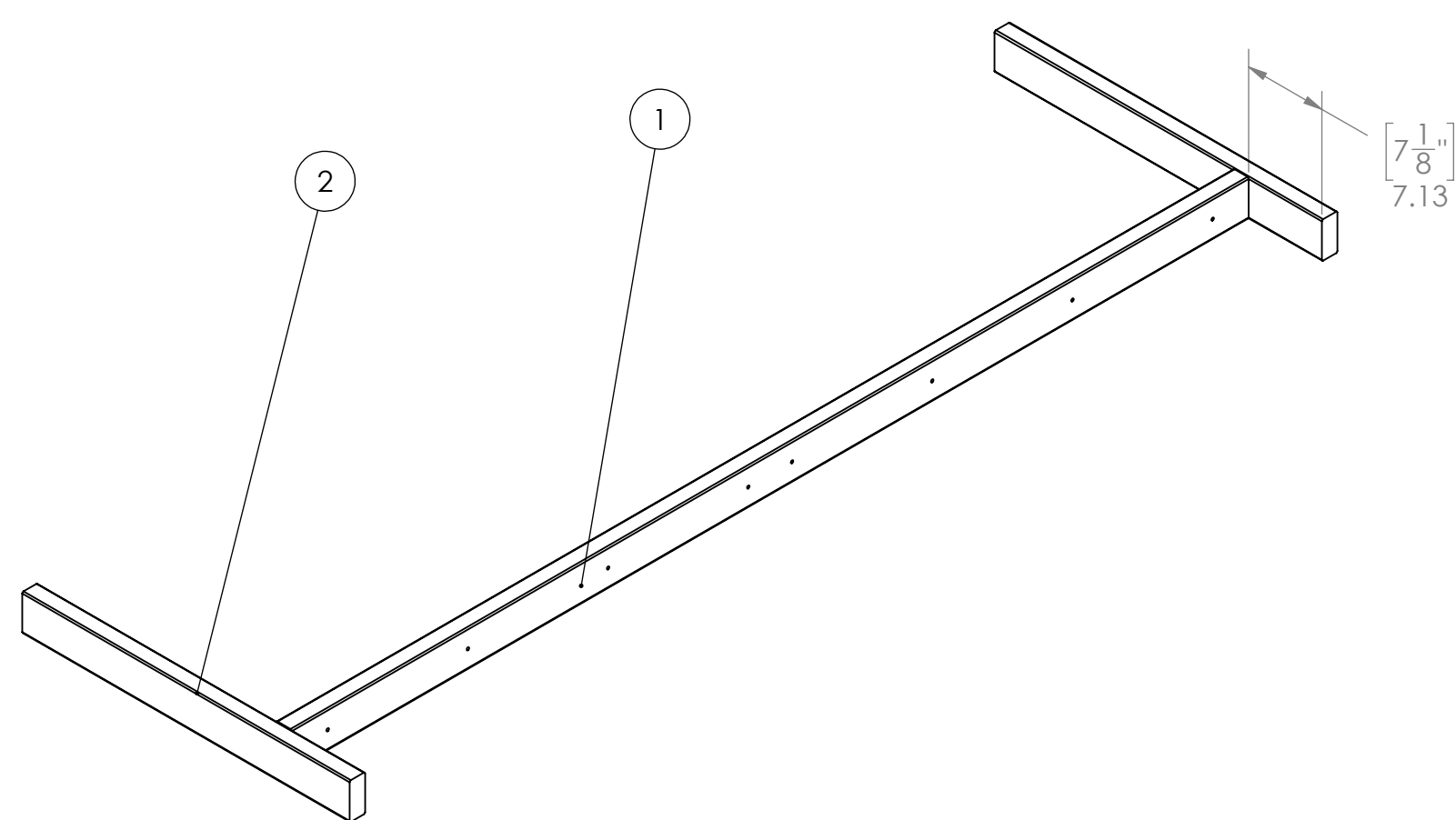

1

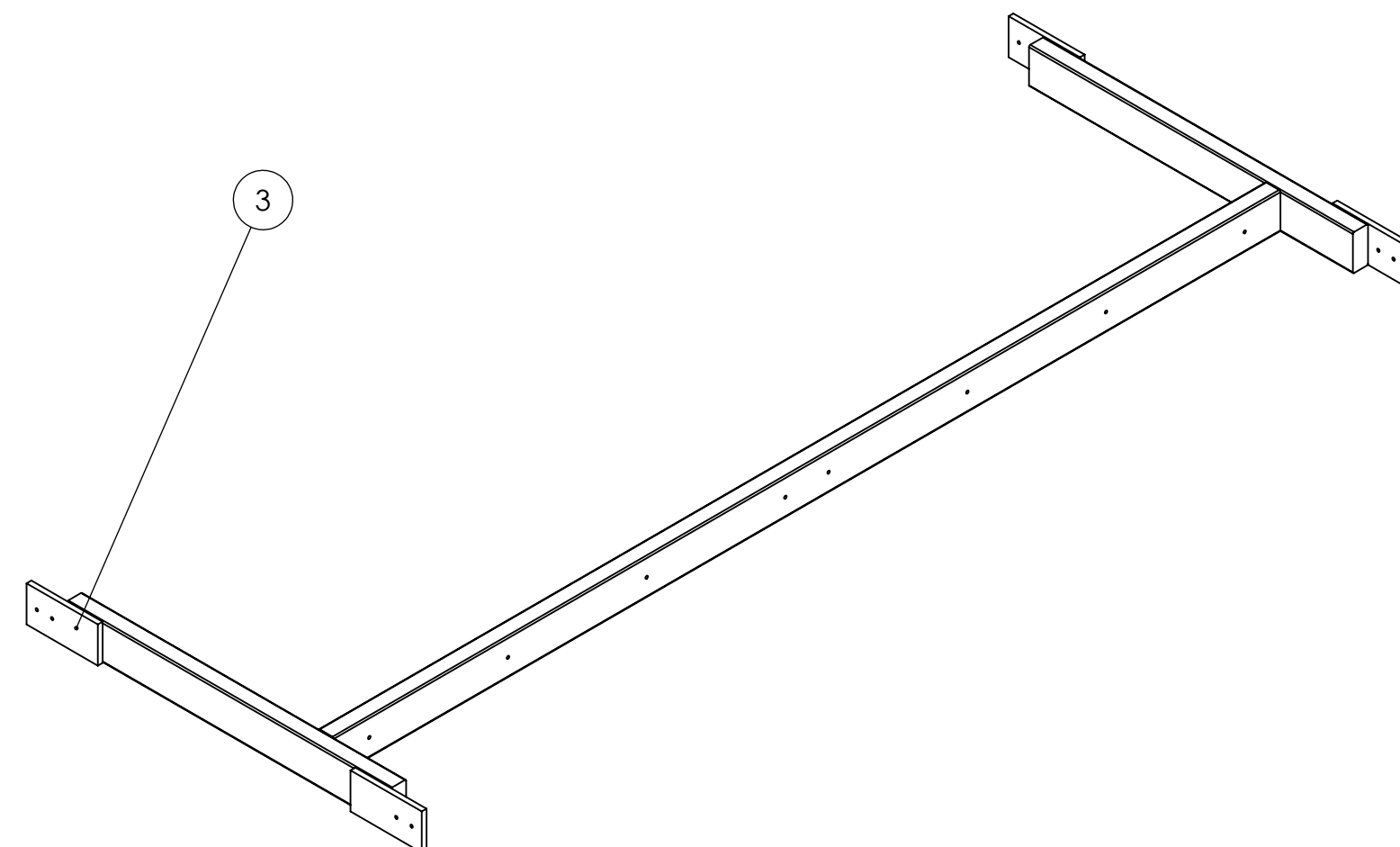

Place Item 2 and 1 attach using wood screws



Attach Item 3 Using wood screws attach overall assembly using bolts and nuts

UNLESS OTHERWISE SPECIFIED: DIMENSIONS ARE IN INCHES TOLERANCES: FRACTIONAL ±1/16 ANGULAR: MACH ±1° BEND ±1° TWO PLACE DECIMAL ±.13 THREE PLACE DECIMAL ±.125 MATERIAL/FINISH: COMMENTS: REMOVE ALL BURRS AND SHARP EDGES. DO NOT SCALE DRAWING	TEAM	NAME	DATE	 
	DRAWN	MS	1/3/2022	
PROPRIETARY AND CONFIDENTIAL THE INFORMATION CONTAINED IN THIS DRAWING IS THE SOLE PROPERTY OF FIRST® . ANY REPRODUCTION IN PART OR AS A WHOLE WITHOUT THE WRITTEN PERMISSION OF FIRST® IS PROHIBITED.				TITLE:
				Support Frame, PF Terminal
SIZE		DWG. NO.	REV	
C		TE-22414		
SCALE: 1:12			SHEET 2 OF 3	

4

3

2

1

D

D

C

C

B

B

A

A

TE-22414-01

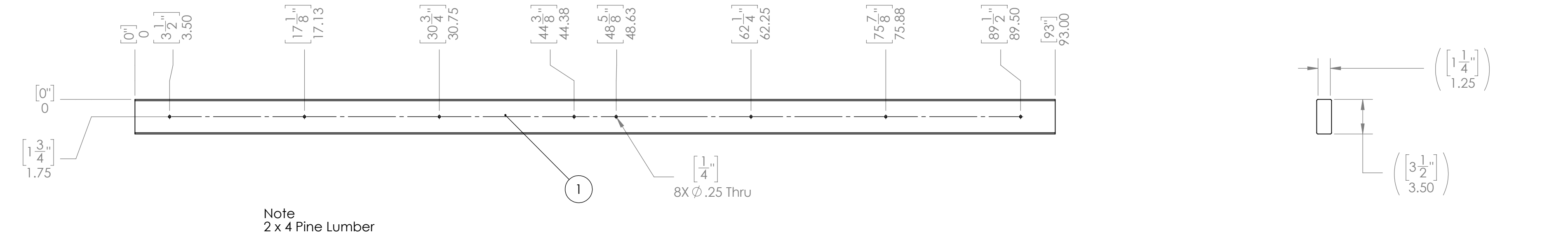

TE-22414-02

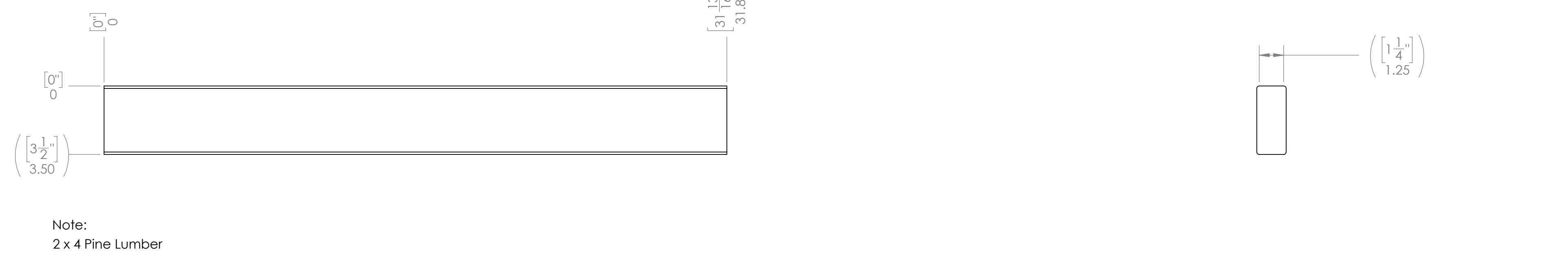

TE-22414-03

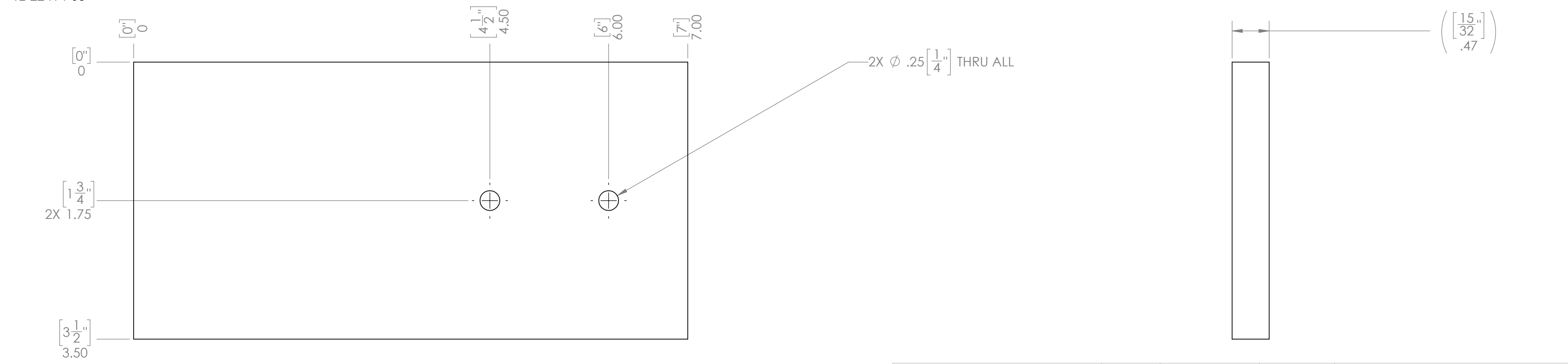

UNLESS OTHERWISE SPECIFIED:	TEAM	NAME	DATE
	DRAWN	MS	1/3/2022
DIMENSIONS ARE IN INCHES TOLERANCES: FRACTIONAL $\pm 1/16$ ANGULAR: MACH $\pm 1^\circ$ BEND $\pm 1^\circ$ TWO PLACE DECIMAL $\pm .13$ THREE PLACE DECIMAL $\pm .125$	PROPRIETARY AND CONFIDENTIAL		
	THE INFORMATION CONTAINED IN THIS DRAWING IS THE SOLE PROPERTY OF FIRST . ANY REPRODUCTION IN PART OR AS A WHOLE WITHOUT THE WRITTEN PERMISSION OF FIRST IS PROHIBITED.		
MATERIAL/FINISH:			
DO NOT SCALE DRAWING	COMMENTS:		TITLE:
	REMOVE ALL BURRS AND SHARP EDGES.		Support Frame, PF Terminal
	SIZE	DWG. NO.	REV
	C	TE-22414	
	SCALE: 1:12	SHEET 3 OF 3	

4

3

2

1

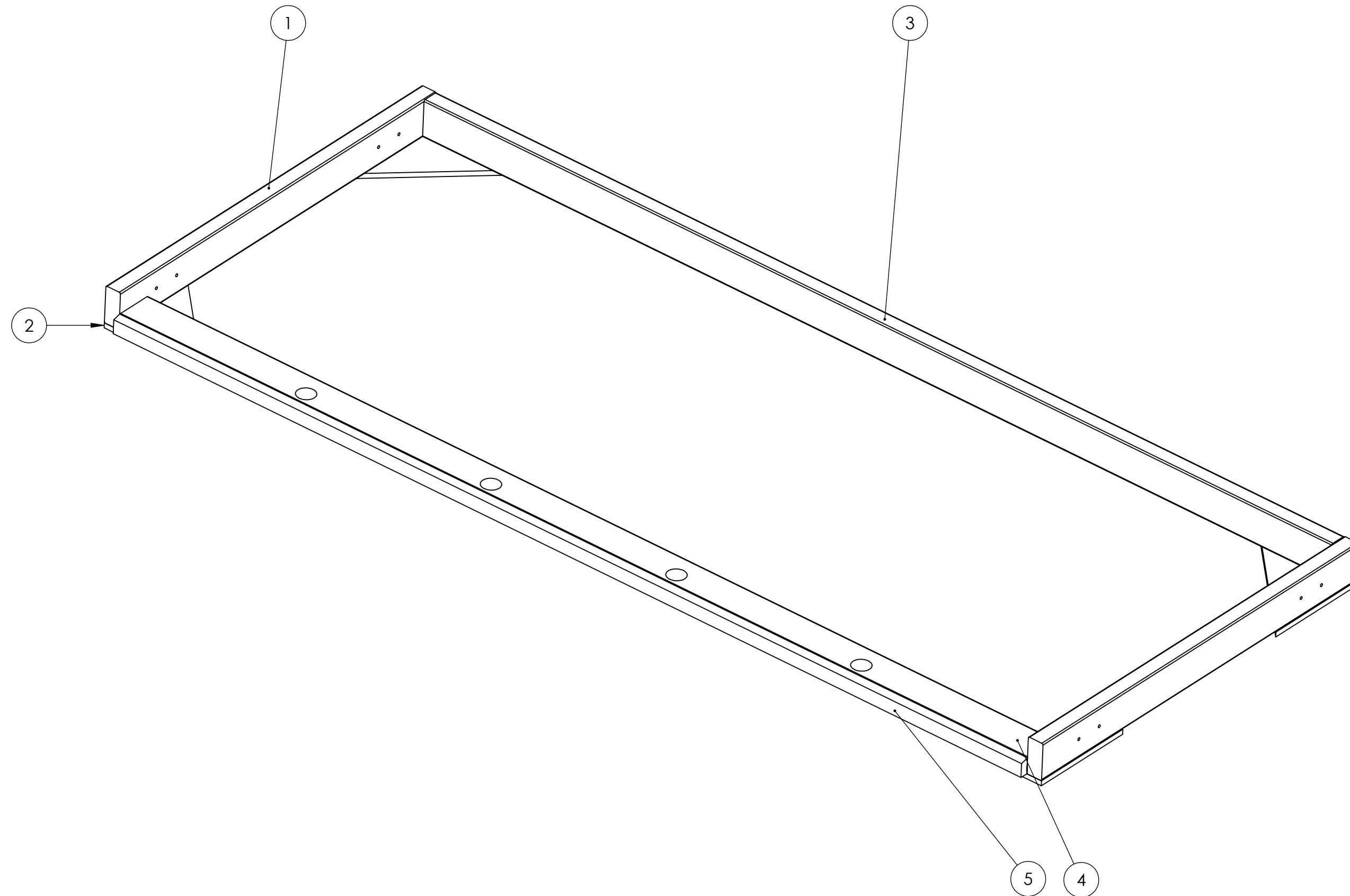

Notes
 Hardware Required:
 #8 Wood Screws x 1.5" long approximately 1 lb
 #8 Wood Screws X 2.5" Long - Approximately 1/4 lbs
 1/4-20 x 2.5" Long Hex Head Bolts - 56 pieces
 1/4-20 Wing Nuts - 56 Pieces
 1/4" flat Washer - 56 pieces

ITEM NO.	PART NUMBER	DESCRIPTION	QTY.
1	TE-22415-01	2x4 Pine Lumber	2
2	TE-22415-03	1/2" Plywood	4
3	TE-22415-04	2x4 Pine Lumber	1
4	TE-22415-05	2x4 Pine Lumber	1
5	TE-22415-06	3/4" Plywood	1

UNLESS OTHERWISE SPECIFIED: DIMENSIONS ARE IN INCHES TOLERANCES: FRACTIONAL ±1/16 ANGULAR: MACH ±1° BEND ±1° TWO PLACE DECIMAL ±.13 THREE PLACE DECIMAL ±.125	TEAM	NAME	DATE
	DRAWN	MS	1/3/2022
MATERIAL/FINISH:	PROPRIETARY AND CONFIDENTIAL		
	THE INFORMATION CONTAINED IN THIS DRAWING IS THE SOLE PROPERTY OF FIRST® . ANY REPRODUCTION IN PART OR AS A WHOLE WITHOUT THE WRITTEN PERMISSION OF FIRST® IS PROHIBITED.		
DO NOT SCALE DRAWING	COMMENTS:		
	REMOVE ALL BURRS AND SHARP EDGES.		



TITLE: Base Frame, PF Terminal		
SIZE	DWG. NO.	REV
C	TE-22415	
SCALE: 1:12	SHEET 1 OF 4	

D

D

C

C

B

B

A

A

4

3

2

1

4

3

2

1

TE-22415-01

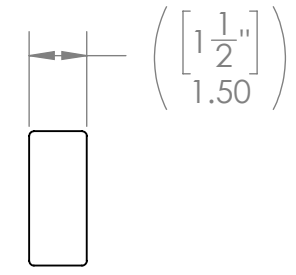
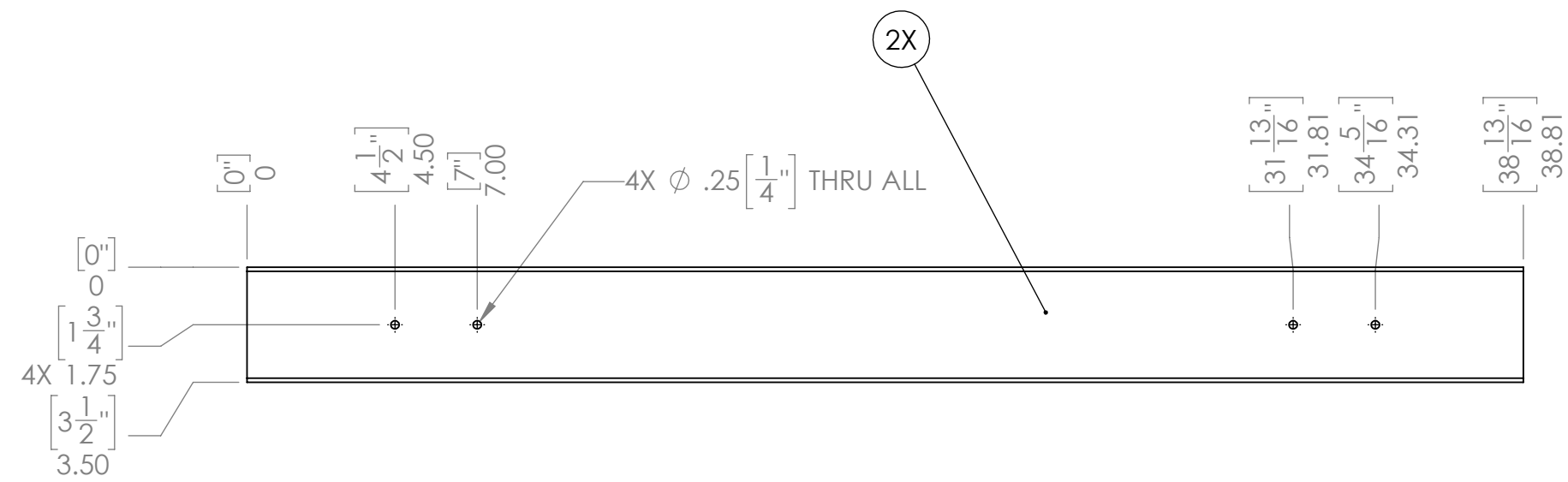

Note:
2x4 Pine Lumber

D

TE-22415-03

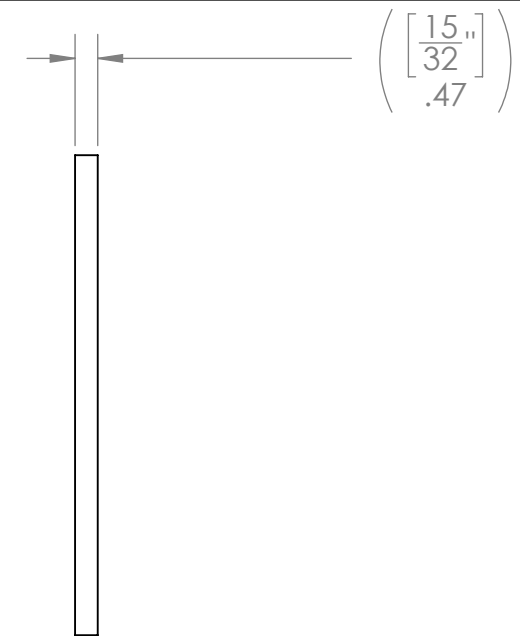
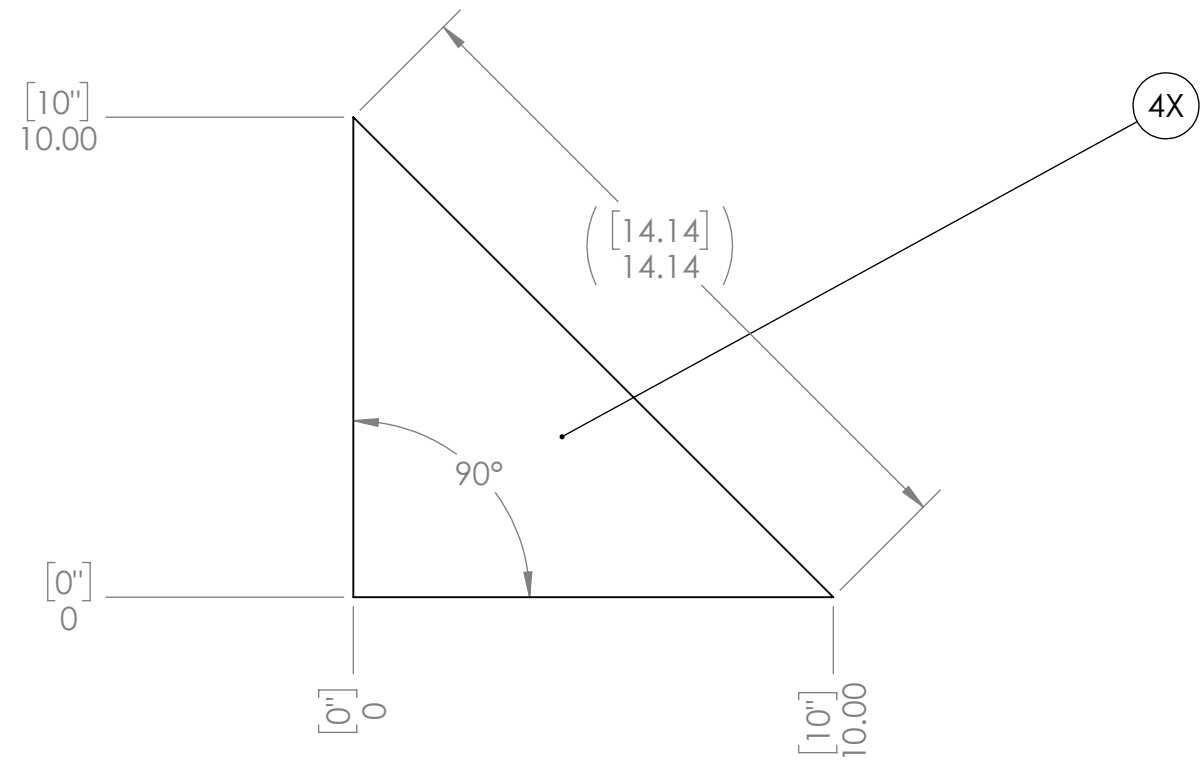

Note:
1/2" Plywood

C

TE-22415-04

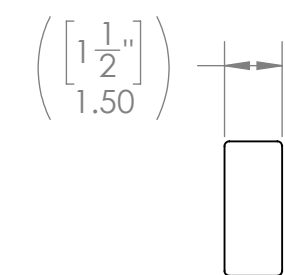
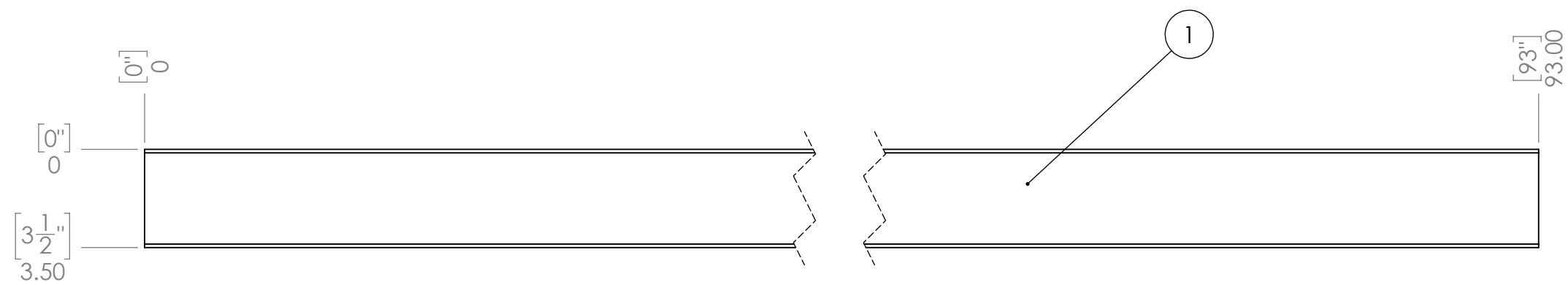

Note:
2x4 Pine Lumber

B

UNLESS OTHERWISE SPECIFIED: DIMENSIONS ARE IN INCHES TOLERANCES: FRACTIONAL ± 1/16 ANGULAR: MACH ± 1° BEND ± 1° TWO PLACE DECIMAL ± .13 THREE PLACE DECIMAL ± .125 MATERIAL/FINISH: DO NOT SCALE DRAWING	TEAM	NAME	DATE
	DRAWN	MS	1/3/2022
	PROPRIETARY AND CONFIDENTIAL		
	THE INFORMATION CONTAINED IN THIS DRAWING IS THE SOLE PROPERTY OF FIRST® . ANY REPRODUCTION IN PART OR AS A WHOLE WITHOUT THE WRITTEN PERMISSION OF FIRST® IS PROHIBITED.		
COMMENTS: REMOVE ALL BURRS AND SHARP EDGES.			



TITLE: Base Frame, PF Terminal		
SIZE	DWG. NO.	REV
C	TE-22415	
SCALE: 1:5		SHEET 2 OF 4

4

3

2

1

A

A

4

3

2

1

TE-22415-05

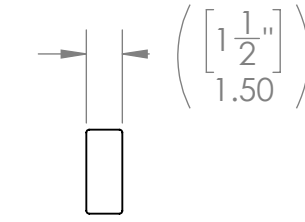
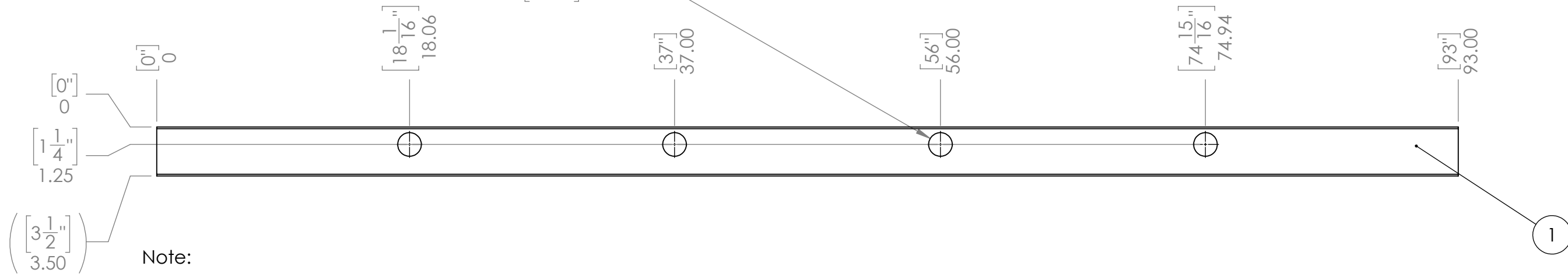

4X Ø 1.69 [1 11/16] THRU

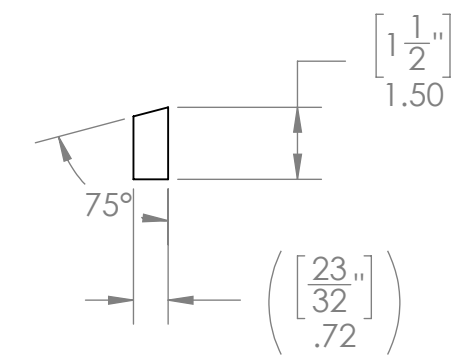
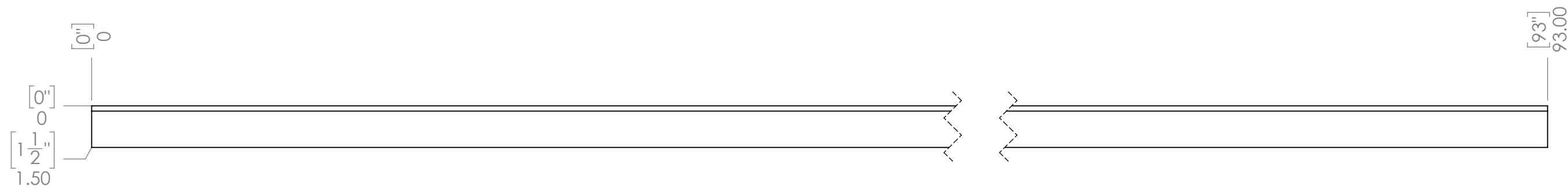

TE-22415-06



Notes:
3/4" Plywood

UNLESS OTHERWISE SPECIFIED:	TEAM	NAME	DATE
	DRAWN	MS	1/3/2022
DIMENSIONS ARE IN INCHES TOLERANCES: FRACTIONAL ± 1/16 ANGULAR: MACH ± 1° BEND ± 1° TWO PLACE DECIMAL ± .13 THREE PLACE DECIMAL ± .125	PROPRIETARY AND CONFIDENTIAL		
	THE INFORMATION CONTAINED IN THIS DRAWING IS THE SOLE PROPERTY OF FIRST® . ANY REPRODUCTION IN PART OR AS A WHOLE WITHOUT THE WRITTEN PERMISSION OF FIRST® IS PROHIBITED.		
MATERIAL/FINISH:	 		
COMMENTS:			
DO NOT SCALE DRAWING	REMOVE ALL BURRS AND SHARP EDGES.		TITLE: <h1>Base Frame, PF Terminal</h1>
	SIZE	DWG. NO.	REV
	C	TE-22415	
	SCALE: 1:12		SHEET 3 OF 4

4

3

2

1

D

D

C

C

B

B

A

A

4

3

2

1

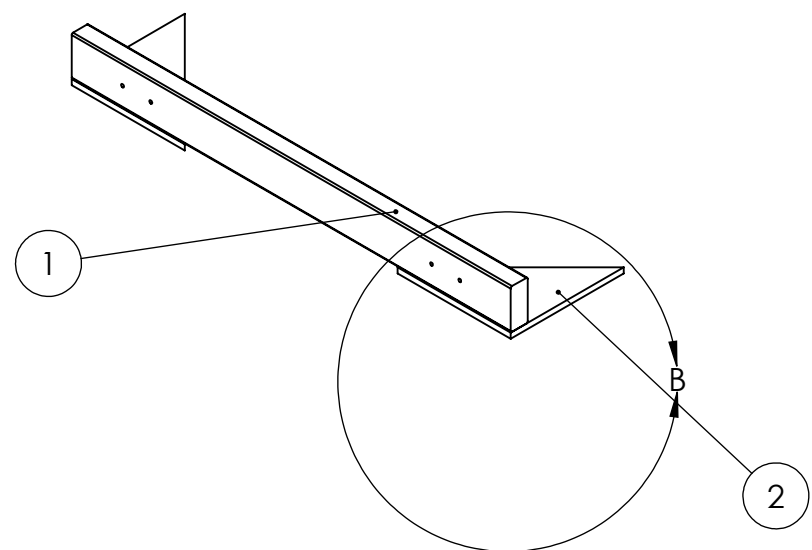
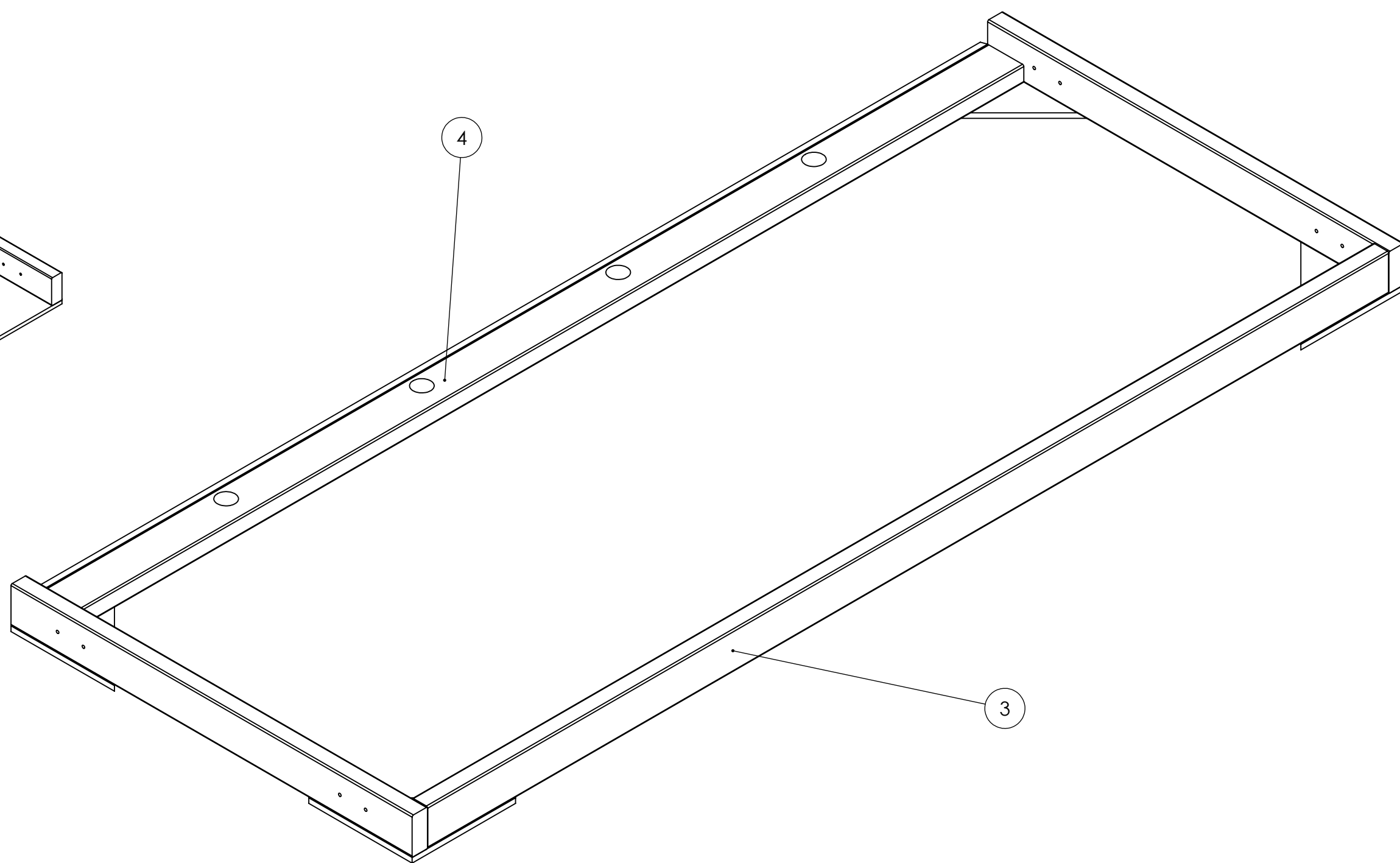
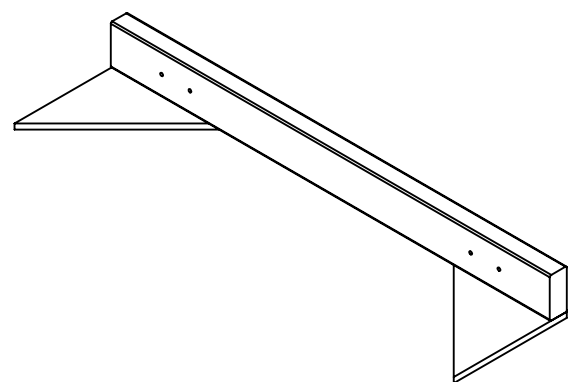

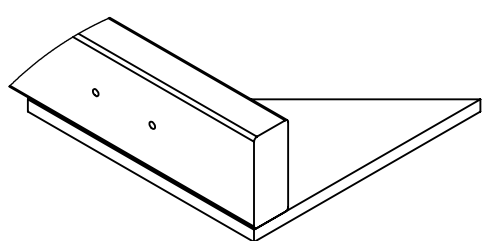

Place Item 1 (1) and all 4 (2) attach with Woodscrews

finish with (3) and (4) using wood screws



DETAIL B
SCALE 1 : 6

UNLESS OTHERWISE SPECIFIED: DIMENSIONS ARE IN INCHES TOLERANCES: FRACTIONAL ±1/16 ANGULAR: MACH ±1° BEND ±1° TWO PLACE DECIMAL ±.13 THREE PLACE DECIMAL ±.125 MATERIAL/FINISH: DO NOT SCALE DRAWING	TEAM	NAME	DATE	 	
	DRAWN	MS	1/3/2022		
PROPRIETARY AND CONFIDENTIAL THE INFORMATION CONTAINED IN THIS DRAWING IS THE SOLE PROPERTY OF FIRST® . ANY REPRODUCTION IN PART OR AS A WHOLE WITHOUT THE WRITTEN PERMISSION OF FIRST® IS PROHIBITED.				TITLE:	
				Base Frame, PF Terminal	
COMMENTS:		REMOVE ALL BURRS AND SHARP EDGES.	SIZE	DWG. NO.	REV
			C	TE-22415	
			SCALE: 1:12	SHEET 4 OF 4	

4

3

2

1

D

D

C

C

B

B

A

A

4

3

2

1

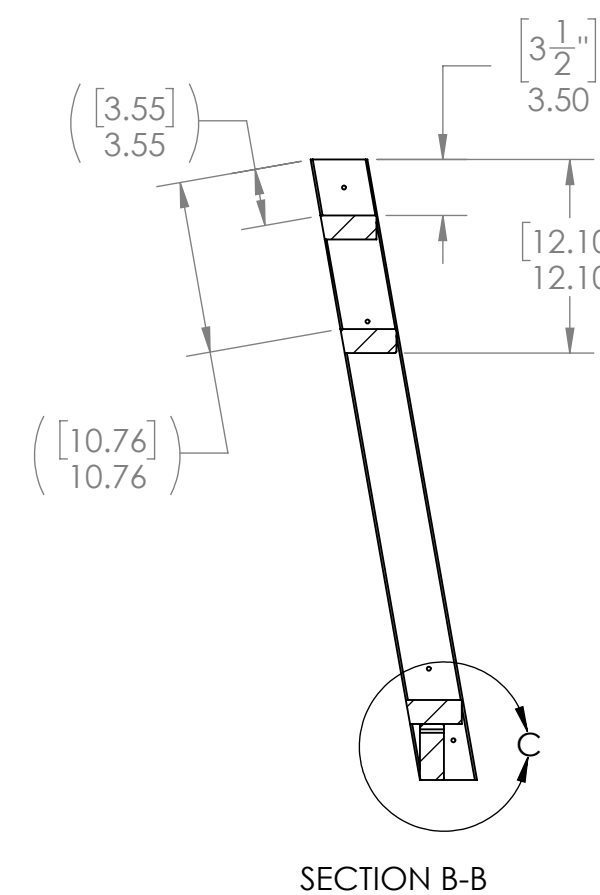
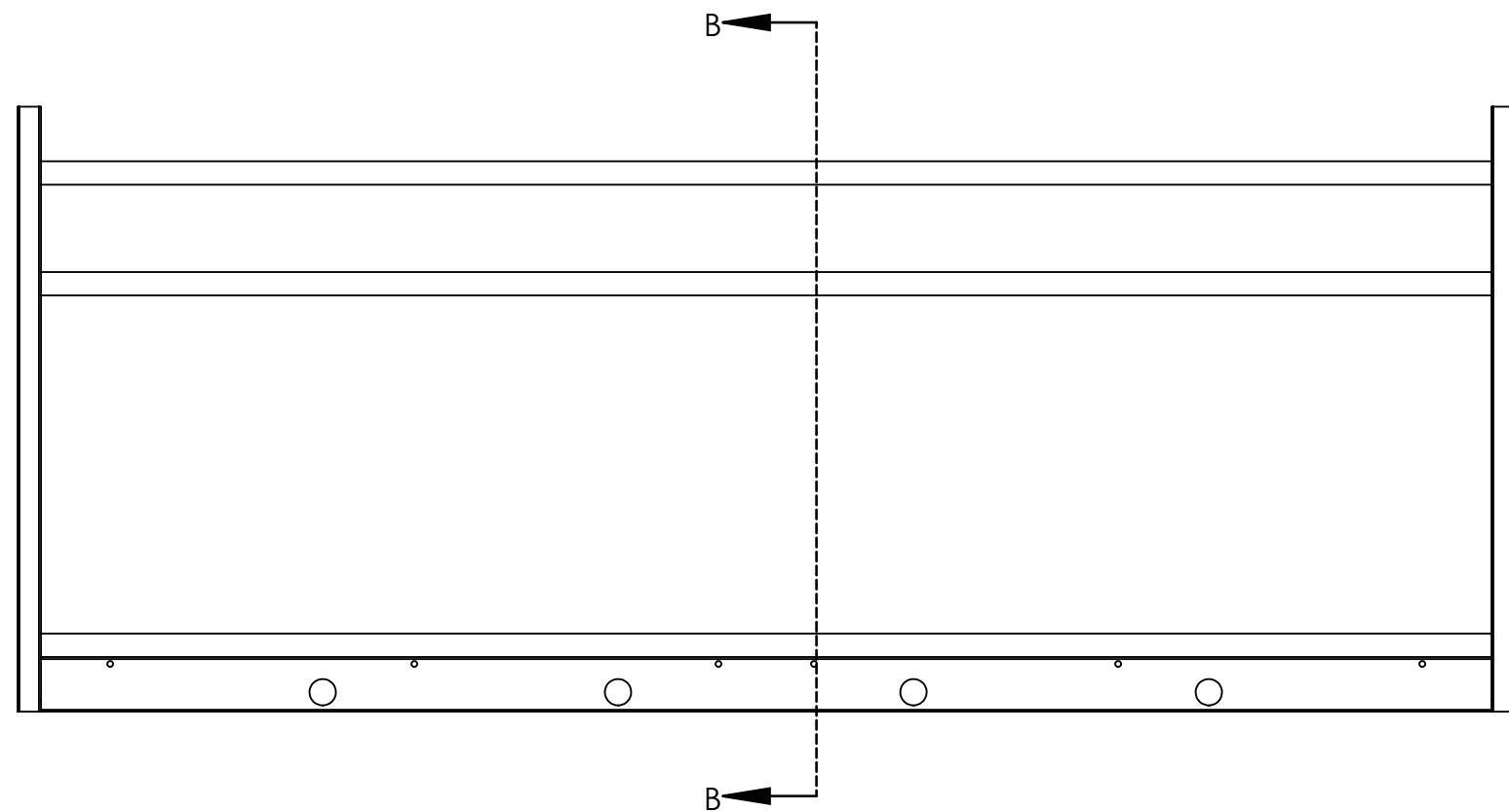
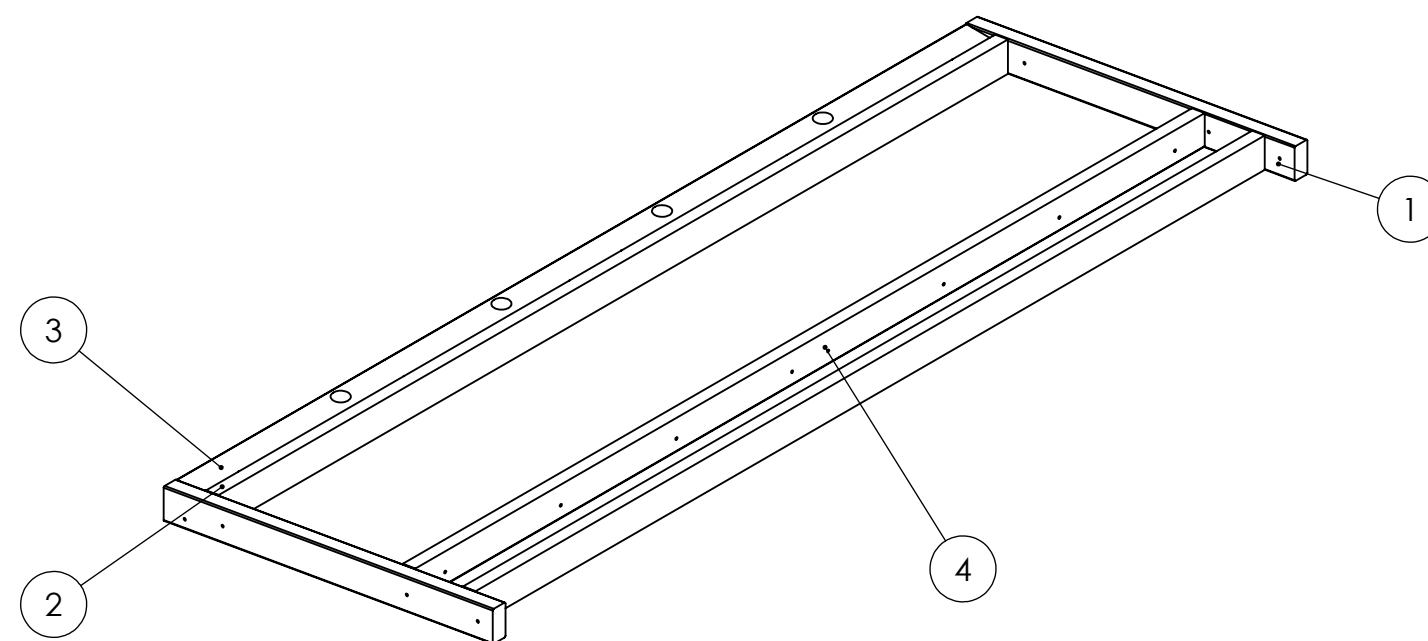
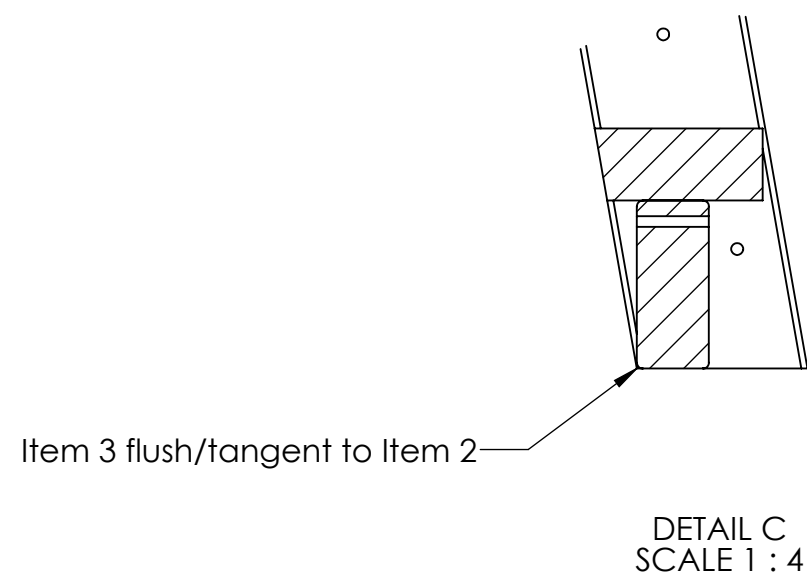

Attach items using 2.5" screws

ITEM NO.	PART NUMBER	DESCRIPTION	QTY.
1	TE-22416-01	2 x 4 Pine Lumber	2
2	TE-22416-02	2 x 4 Pine Lumber	2
3	TE-22416-03	2 x 4 Pine Lumber	1
4	TE-22416-04	2 x 4 Pine Lumber	1

UNLESS OTHERWISE SPECIFIED: DIMENSIONS ARE IN INCHES TOLERANCES: FRACTIONAL ± 1/16 ANGULAR: MACH ± 1° BEND ± 1° TWO PLACE DECIMAL ± .13 THREE PLACE DECIMAL ± .125	TEAM	NAME	DATE
	DRAWN	MS	1/3/2022
MATERIAL/FINISH:	PROPRIETARY AND CONFIDENTIAL THE INFORMATION CONTAINED IN THIS DRAWING IS THE SOLE PROPERTY OF FIRST® . ANY REPRODUCTION IN PART OR AS A WHOLE WITHOUT THE WRITTEN PERMISSION OF FIRST® IS PROHIBITED.		
COMMENTS:	REMOVE ALL BURRS AND SHARP EDGES.		
DO NOT SCALE DRAWING			



TITLE: Support Frame Long, PF Terminal		
SIZE	DWG. NO.	REV
C	TE-22416	
SCALE: 1:12	SHEET 1 OF 3	

4

3

2

1

4

3

2

1

TE-22416-01

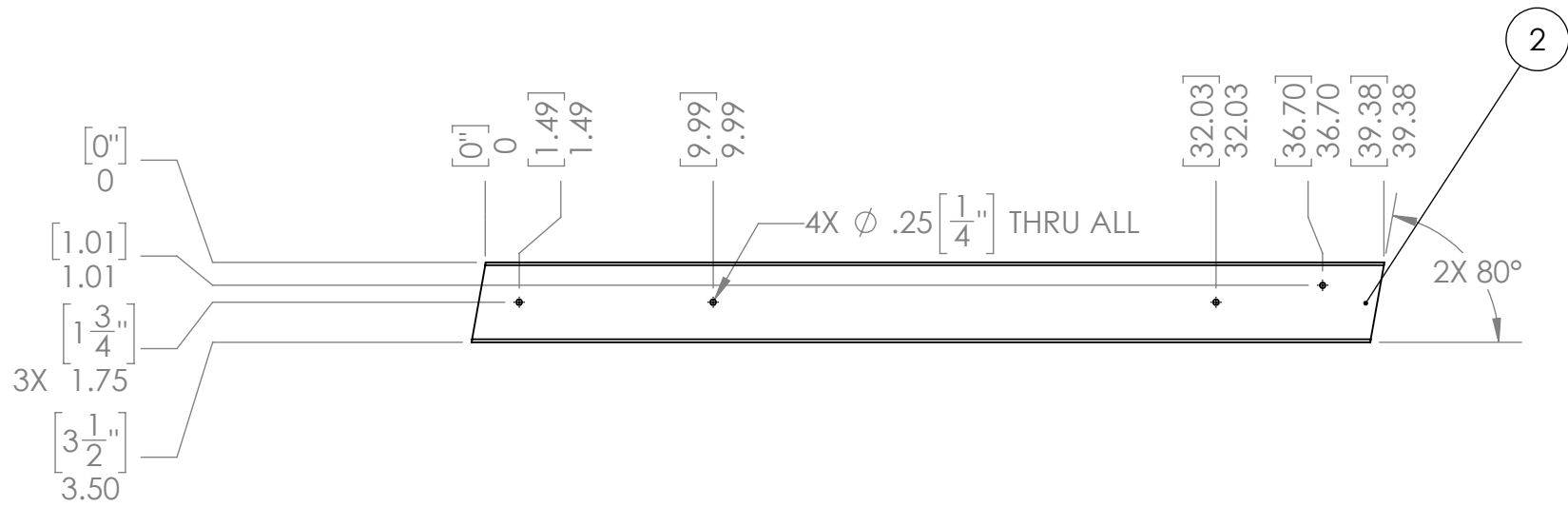

Notes:
2 x 4 Pine Lumber

TE-22416-02

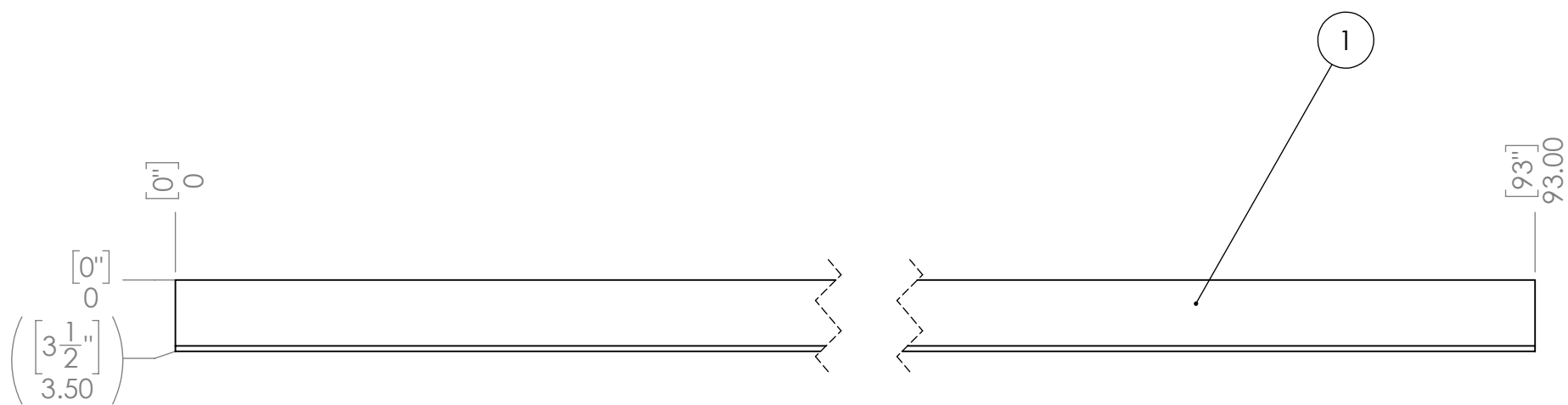

Notes:
2 x 4 Pine Lumber

TE-22416-03

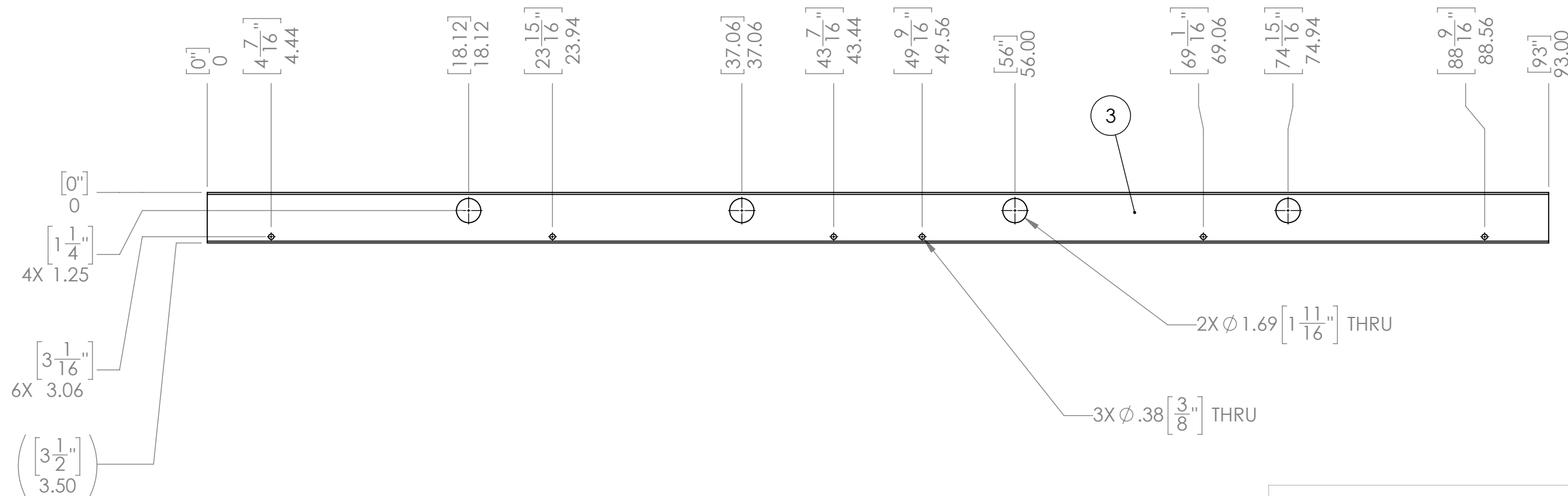

Notes:
2 x 4 Pine Lumber

UNLESS OTHERWISE SPECIFIED: DIMENSIONS ARE IN INCHES TOLERANCES: FRACTIONAL ± 1/16 ANGULAR: MACH ± 1° BEND ± 1° TWO PLACE DECIMAL ± .13 THREE PLACE DECIMAL ± .125	TEAM	NAME	DATE
	DRAWN	MS	1/3/2022
MATERIAL/FINISH:	PROPRIETARY AND CONFIDENTIAL		
COMMENTS: REMOVE ALL BURRS AND SHARP EDGES.	THE INFORMATION CONTAINED IN THIS DRAWING IS THE SOLE PROPERTY OF FIRST® . ANY REPRODUCTION IN PART OR AS A WHOLE WITHOUT THE WRITTEN PERMISSION OF FIRST® IS PROHIBITED.		
	DO NOT SCALE DRAWING		

FIRST ROBOTICS COMPETITION **SOLIDWORKS** Modeling Solutions Partner

TITLE: **Support Frame Long, PF Terminal**

SIZE	DWG. NO.	REV
C	TE-22416	
SCALE: 1:8		SHEET 2 OF 3

4

3

2

1

D

D

C

C

B

B



A

A

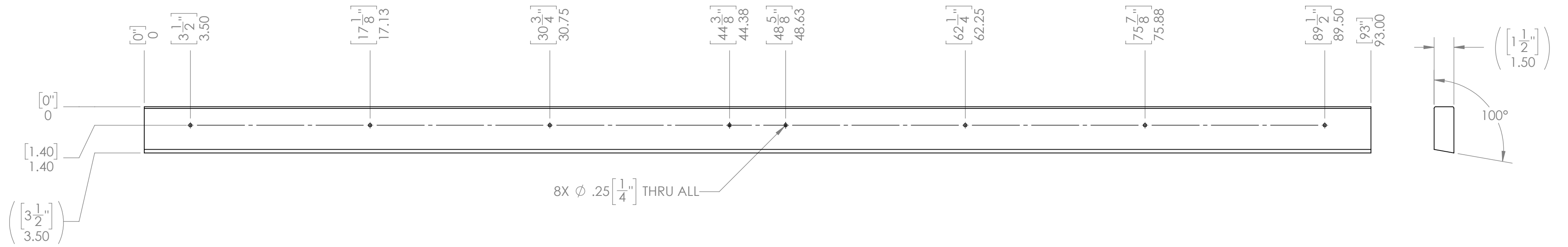
TE-22416-04



Notes:
2 x 4 Pine Lumber

UNLESS OTHERWISE SPECIFIED: DIMENSIONS ARE IN INCHES TOLERANCES: FRACTIONAL $\pm 1/16$ ANGULAR: MACH $\pm 1^\circ$ BEND $\pm 1^\circ$ TWO PLACE DECIMAL $\pm .13$ THREE PLACE DECIMAL $\pm .125$ MATERIAL/FINISH: DO NOT SCALE DRAWING	TEAM	NAME	DATE	 
	DRAWN	MS	1/3/2022	
	PROPRIETARY AND CONFIDENTIAL			TITLE:
	THE INFORMATION CONTAINED IN THIS DRAWING IS THE SOLE PROPERTY OF FIRST . ANY REPRODUCTION IN PART OR AS A WHOLE WITHOUT THE WRITTEN PERMISSION OF FIRST IS PROHIBITED.			Support Frame Long, PF Terminal
	COMMENTS: REMOVE ALL BURRS AND SHARP EDGES.			SIZE
				DWG. NO.
				REV
				C TE-22416
				SCALE: 1:12
				SHEET 3 OF 3

4

3

2

1

D

D

C

C

B

B

A

A

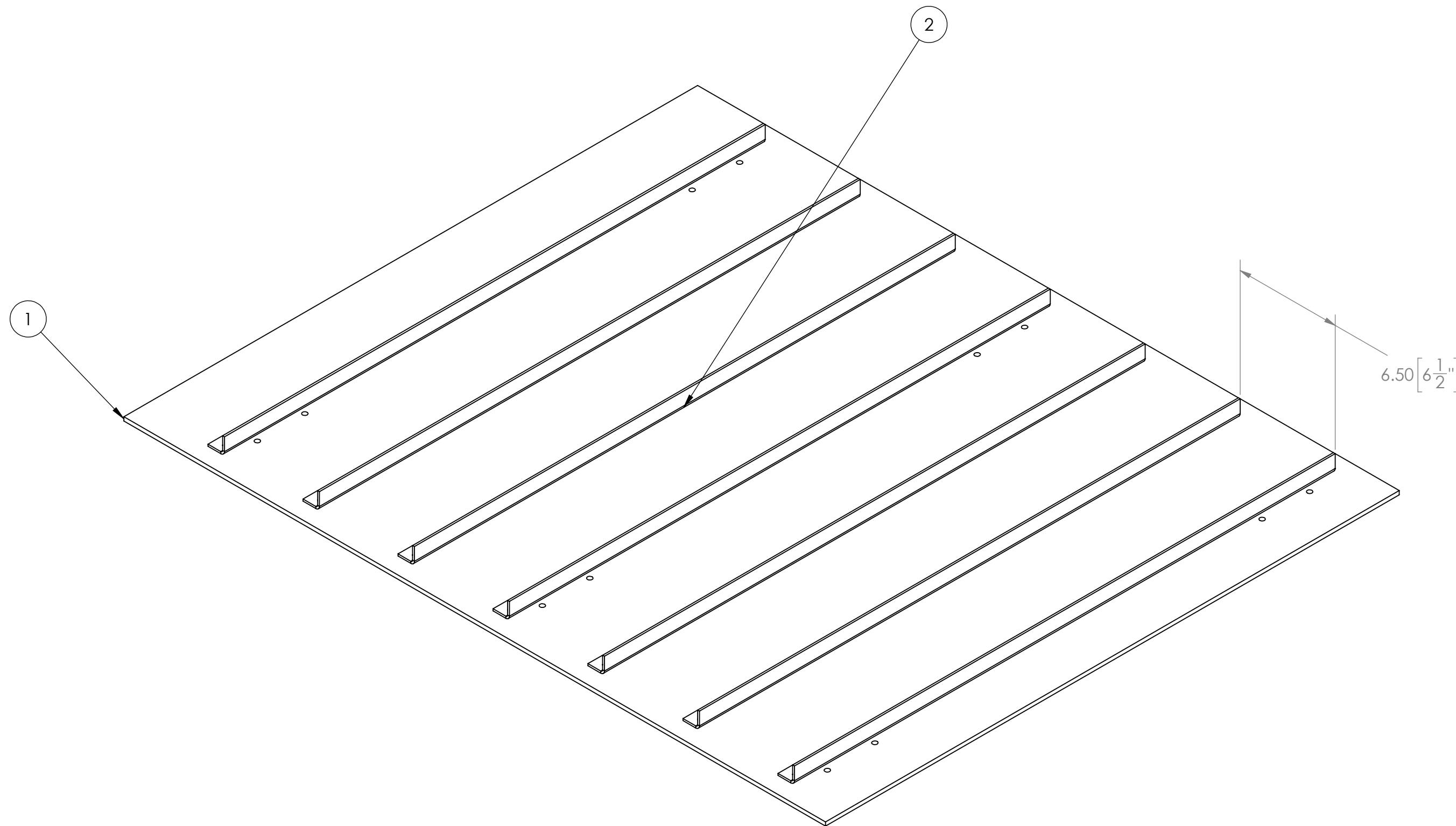

Notes:
 Hardware Required
 Staples and/or Glue

Optional: #10 bolts (~3/4" long, depending on thickness of material used for (2)) and nuts, QTY 28.

If teams do not want to use bolts to secure (2) to (1), a number of holes in these parts may be omitted.

ITEM NO.	PART NUMBER	DESCRIPTION	QTY.
1	TE-22418	Bed, Chute Assembly	1
2	TE-22419	Angle, Chute Assembly	7

UNLESS OTHERWISE SPECIFIED:

DIMENSIONS ARE IN INCHES
 TOLERANCES:
 FRACTIONAL ±1/16
 ANGULAR: MACH ±1° BEND ±1°
 TWO PLACE DECIMAL ±.13
 THREE PLACE DECIMAL ±.125

MATERIAL/FINISH:

DO NOT SCALE DRAWING

TEAM	NAME	DATE
DRAWN	MS	1/4/2022

PROPRIETARY AND CONFIDENTIAL
 THE INFORMATION CONTAINED IN THIS DRAWING IS THE SOLE PROPERTY OF **FIRST®**. ANY REPRODUCTION IN PART OR AS A WHOLE WITHOUT THE WRITTEN PERMISSION OF **FIRST®** IS PROHIBITED.

COMMENTS:
 REMOVE ALL BURRS AND SHARP EDGES.



TITLE:
Chute Assembly, Terminal

SIZE	DWG. NO.	REV
C	TE-22417	

SCALE: 1:5 SHEET 1 OF 2

4

3

2

1

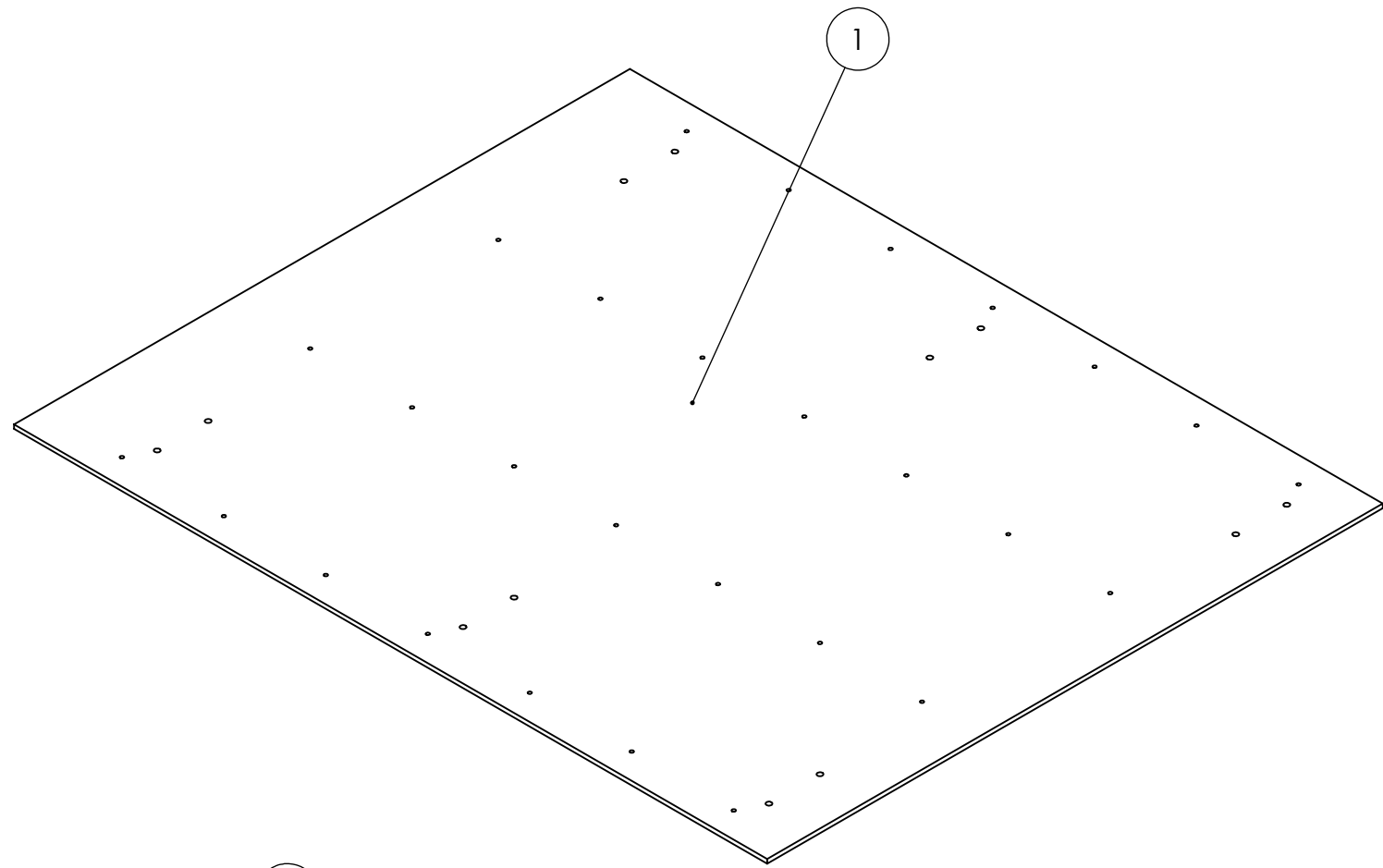

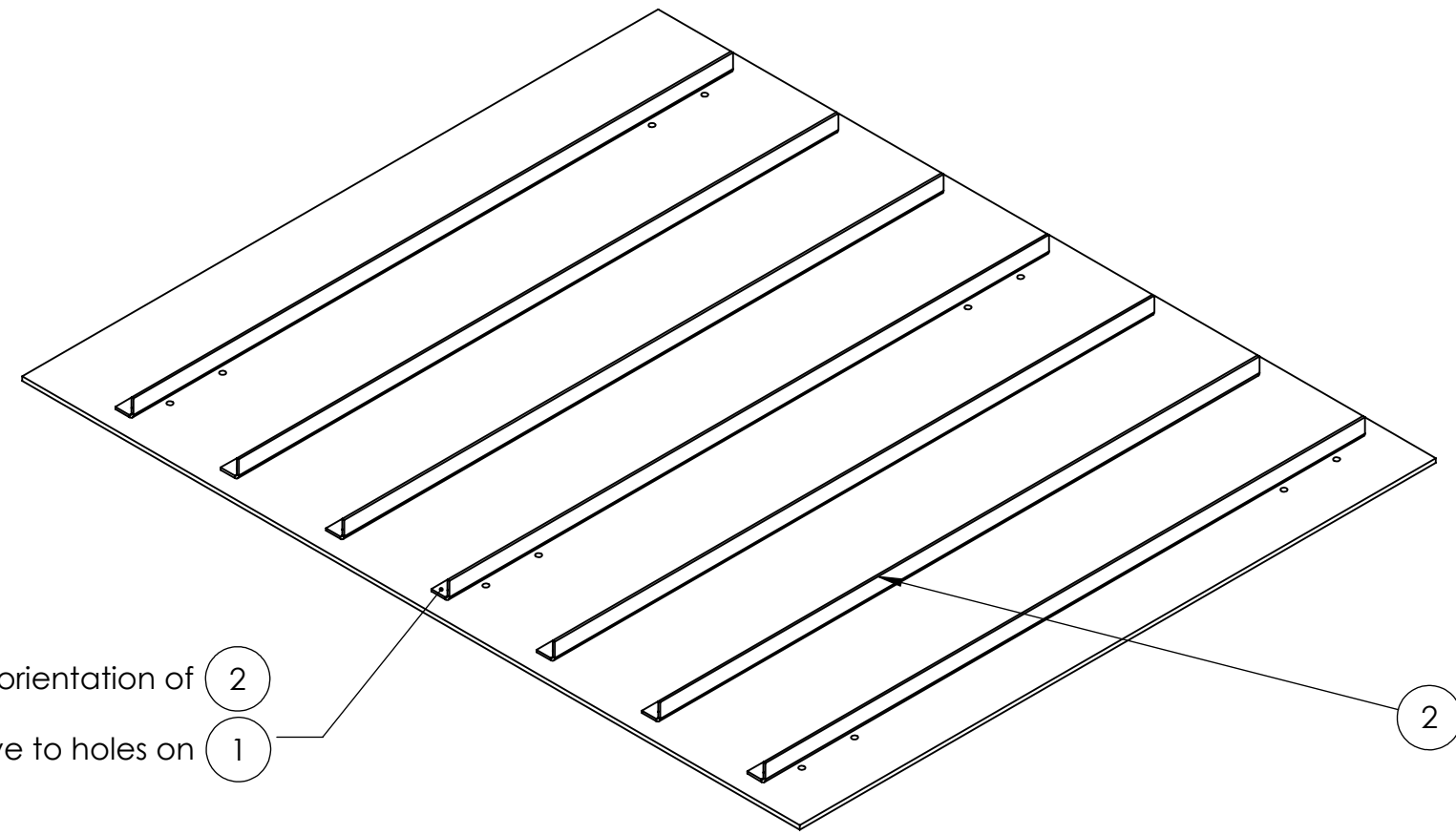

Place Item 1

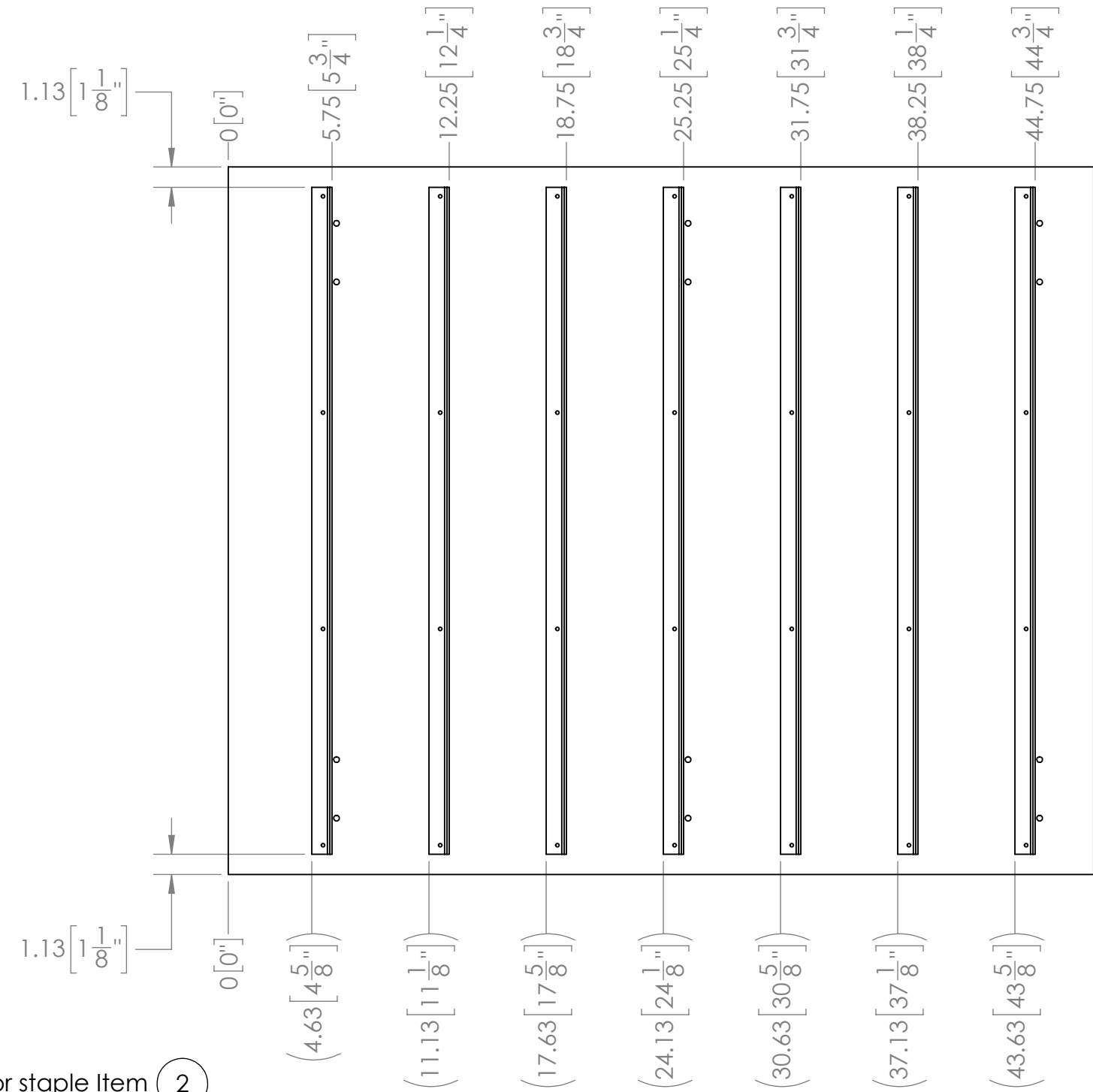

Note orientation of 2 relative to holes on 1



Glue and/or staple Item 2
Optional: attach using nuts and bolts

UNLESS OTHERWISE SPECIFIED: DIMENSIONS ARE IN INCHES TOLERANCES: FRACTIONAL ± 1/16 ANGULAR: MACH ± 1° BEND ± 1° TWO PLACE DECIMAL ± .13 THREE PLACE DECIMAL ± .125 MATERIAL/FINISH: DO NOT SCALE DRAWING	TEAM	NAME	DATE	 	
	DRAWN	MS	1/4/2022		
	PROPRIETARY AND CONFIDENTIAL THE INFORMATION CONTAINED IN THIS DRAWING IS THE SOLE PROPERTY OF FIRST®. ANY REPRODUCTION IN PART OR AS A WHOLE WITHOUT THE WRITTEN PERMISSION OF FIRST® IS PROHIBITED.			TITLE: <h2>Chute Assembly, Terminal</h2>	
	COMMENTS: REMOVE ALL BURRS AND SHARP EDGES.			SIZE C	DWG. NO. TE-22417
			SCALE: 1:8	REV	
			SHEET 2 OF 2		

4

3

2

1

D

D

C

C

B

B

A

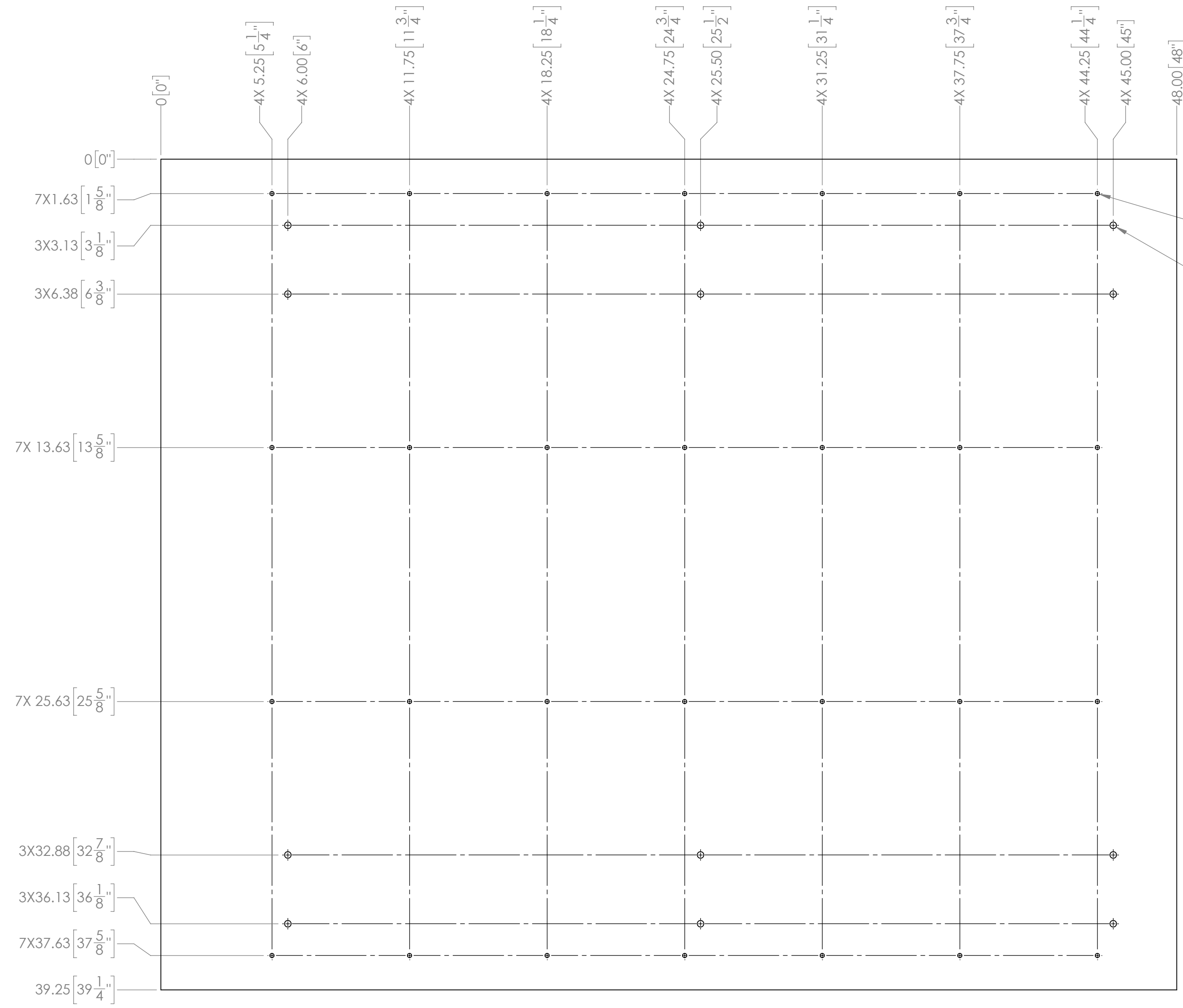

A



28X ϕ .20 [.20] THRU ALL
Optional, see note

12X ϕ .31 [$\frac{5}{16}$] THRU

Notes:
1. ϕ .20" diameter holes are optional - see TE-22417 for details.

UNLESS OTHERWISE SPECIFIED: DIMENSIONS ARE IN INCHES TOLERANCES: FRACTIONAL $\pm 1/16$ ANGULAR: MACH $\pm 1^\circ$ BEND $\pm 1^\circ$ TWO PLACE DECIMAL $\pm .13$ THREE PLACE DECIMAL $\pm .125$ MATERIAL/FINISH: 1/4" Plywood or Hardboard DO NOT SCALE DRAWING	TEAM	NAME	DATE	 
	DRAWN	MS	1/4/2022	
PROPRIETARY AND CONFIDENTIAL THE INFORMATION CONTAINED IN THIS DRAWING IS THE SOLE PROPERTY OF FIRST . ANY REPRODUCTION IN PART OR AS A WHOLE WITHOUT THE WRITTEN PERMISSION OF FIRST IS PROHIBITED.				TITLE: Bed, Chute Assembly
COMMENTS: REMOVE ALL BURRS AND SHARP EDGES.				SIZE DWG. NO. REV C TE-22418
SCALE: 1:8			SHEET 1 OF 1	

4

3

2

1

4

3

2

1

D

D

C

C

B



B

A

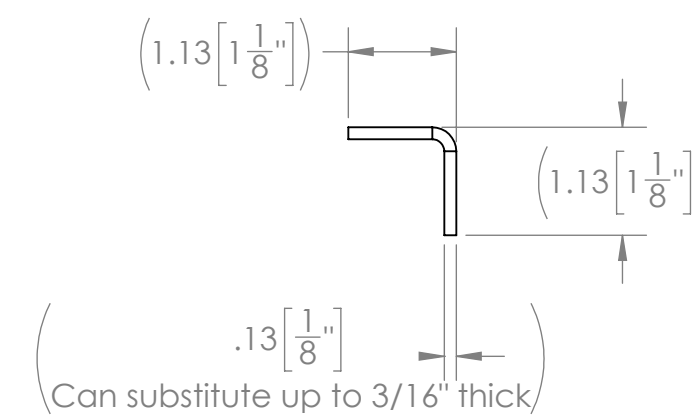
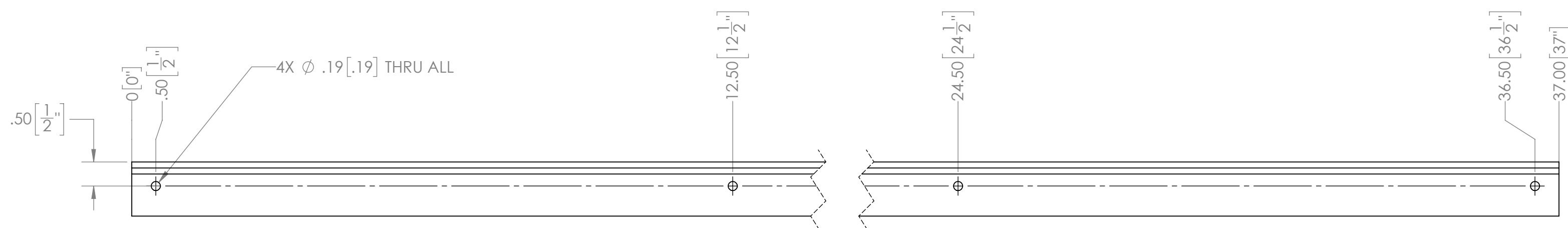
A



Notes:
 1. .019" diameter holes are optional, see TE-22417 for details.

UNLESS OTHERWISE SPECIFIED: DIMENSIONS ARE IN INCHES TOLERANCES: FRACTIONAL ± 1/2 ANGULAR: MACH ± 1° BEND ± 1° TWO PLACE DECIMAL ± .50 MATERIAL/FINISH: 1-1/8" x 1-1/8" x 37" Long Outside Corner Moulding, 1/8"- 3/16" thick DO NOT SCALE DRAWING	FIELD	NAME	DATE	 
	DRAWN	MS	1/5/2022	
	PROPRIETARY AND CONFIDENTIAL			TITLE:
	THE INFORMATION CONTAINED IN THIS DRAWING IS THE SOLE PROPERTY OF FIRST® . ANY REPRODUCTION IN PART OR AS A WHOLE WITHOUT THE WRITTEN PERMISSION OF FIRST® IS PROHIBITED.			Angle, Chute Assembly
	COMMENTS: REMOVE ALL BURRS AND SHARP EDGES.			SIZE
				DWG. NO.
			REV	
			C	TE-22419
			SCALE: 1:4	SHEET 1 OF 1

4

3

2

1