



## 8 ROBOT Rules

---

This section of the 2018 *FIRST*<sup>®</sup> Robotics Competition Game Manual presents legislation relevant to the construction of a 2018 *FIRST*<sup>®</sup> Robotics Competition ROBOT. ROBOTS must pass Inspection at each *FIRST*<sup>®</sup> Robotics Competition event to confirm compliance before being allowed to compete, per [Section 9 Eligibility & Inspection](#).

### 8.1 Overview

---

The rules listed below explicitly address legal parts and materials and how those parts and materials may be used on a 2018 ROBOT. There are many reasons for the structure of the rules, including safety, reliability, parity, creation of a reasonable design challenge, adherence to professional standards, impact on the competition, and compatibility with the Kit of Parts (KOP). The KOP is the collection of items listed on any Kickoff Kit Checklists, distributed via *FIRST*<sup>®</sup> Choice, or paid for completely (except shipping) with a Product Donation Voucher (PDV).

Another intent of these rules is to have all energy sources and active actuation systems on the ROBOT (e.g. batteries, compressors, motors, servos, cylinders, and their controllers) drawn from a well-defined set of options. This is to ensure that all teams have access to the same actuation resources and that the Inspectors are able to accurately and efficiently assess the legality of a given part.

ROBOTS are made up of COMPONENTS and MECHANISMS. A COMPONENT is any part in its most basic configuration, which cannot be disassembled without damaging or destroying the part or altering its fundamental function. A MECHANISM is a COTS or custom assembly of COMPONENTS that provide specific functionality on the ROBOT. A MECHANISM can be disassembled (and then reassembled) into individual COMPONENTS without damage to the parts.

Many rules in this section reference Commercial-Off-The-Shelf (COTS) items. A COTS item must be a standard (i.e. not custom order) part commonly available from a VENDOR for all teams for purchase. To be a COTS item, the COMPONENT or MECHANISM must be in an unaltered, unmodified state (with the exception of installation or modification of any software). Items that are no longer commercially available but are functionally equivalent to the original condition as delivered from the VENDOR are considered COTS and may be used.

- Example 1: A Team orders two (2) ROBOT grippers from RoboHands Corp. and receives both items. They put one in their storeroom and plan to use it later. Into the other, they drill “lightening holes” to reduce weight. The first gripper is still classified as a COTS item, but the second gripper is now a FABRICATED ITEM, as it has been modified.
- Example 2: A Team obtains openly available blueprints of a drive module commonly available from Wheels-R-Us Inc. and has local machine shop “We-Make-It, Inc.” manufacture a copy of the part for them. The produced part is NOT a COTS item, because it is not commonly carried as part of the standard stock of We-Make-It, Inc.
- Example 3: A Team obtains openly available design drawings from a professional publication during the pre-season, and uses them to fabricate a gearbox for their ROBOT during the build period following Kickoff. The design drawings are considered a COTS item, and may be used as “raw material” to fabricate the gearbox. The finished gearbox itself would be a FABRICATED ITEM, and not a COTS item.



- Example 4: A COTS part that has non-functional label markings added would still be considered a COTS part, but a COTS part that has device-specific mounting holes added is a FABRICATED ITEM.
- Example 5: A team has a COTS single-board processor version 1.0, which can no longer be purchased. Only the COTS single-board processor version 2.0 may be purchased. If the COTS single-board processor version 1.0 is functionally equivalent to its original condition, it may be used.
- Example 6: A team has a COTS gearbox which has been discontinued. If the COTS gearbox is functionally equivalent to its original condition, it may be used.

A **VENDOR** is a legitimate business source for COTS items that satisfies all of the following criteria:

- A. has a Federal Tax Identification number. In cases where the **VENDOR** is outside of the United States, they must possess an equivalent form of registration or license with the government of their home nation that establishes and validates their status as a legitimate business licensed to operate within that country.
- B. is not a “wholly owned subsidiary” of a *FIRST* Robotics Competition Team or collection of Teams. While there may be some individuals affiliated with both a Team and the **VENDOR**, the business and activities of the Team and **VENDOR** must be completely separable.
- C. must be able to ship any general (i.e., non-*FIRST* unique) product within five business days of receiving a valid purchase request. It is recognized that certain unusual circumstances (such as 1,000 *FIRST* Teams all ordering the same part at once from the same **VENDOR**) may cause atypical delays in shipping due to backorders for even the largest **VENDORS**. Such delays due to higher-than-normal order rates are excused.
- D. should maintain sufficient stock or production capability to fill Teams’ orders within a reasonable period during the season (less than 1 week). (Note that this criterion may not apply to custom-built items from a source that is both a **VENDOR** and a fabricator. For example, a **VENDOR** may sell flexible belting that the Team wishes to procure to use as treads on their drive system. The **VENDOR** cuts the belting to a custom length from standard shelf stock that is typically available, welds it into a loop to make a tread, and ships it to a Team. The fabrication of the tread takes the **VENDOR** two weeks. This would be considered a FABRICATED ITEM, and the two-week ship time is acceptable.) Alternately, the Team may decide to fabricate the treads themselves. To satisfy this criterion, the **VENDOR** would just have to ship a length of belting from shelf stock (i.e. a COTS item) to the Team within five business days and leave the welding of the cuts to the Team.)
- E. makes their products available to all *FIRST* Robotics Competition Teams. A **VENDOR** must not limit supply or make a product available to just a limited number of *FIRST* Robotics Competition Teams.

The intent of this definition is to be as inclusive as possible to permit access to all legitimate sources, while preventing ad hoc organizations from providing special-purpose products to a limited subset of Teams in an attempt to circumvent the cost accounting rules.

*FIRST* desires to permit Teams to have the broadest choice of legitimate sources possible, and to obtain COTS items from the sources that

provide them with the best prices and level of service available. Teams also need to protect against long delays in availability of parts that will impact their ability to complete their ROBOT. The build season is brief, so the VENDOR must be able to get their product, particularly *FIRST* unique items, to a Team in a timely manner.

Ideally, chosen VENDORS should have national distributors (e.g. Home Depot, Lowes, MSC, Radio Shack, McMaster-Carr, etc.). Remember, *FIRST* Robotics Competition events are not always near home – when parts fail, local access to replacement materials is often critical.

A FABRICATED ITEM is any COMPONENT or MECHANISM that has been altered, built, cast, constructed, concocted, created, cut, heat treated, machined, manufactured, modified, painted, produced, surface coated, or conjured partially or completely into the final form in which it will be used on the ROBOT.

Note that it is possible for an item (typically raw materials) to be neither COTS nor a FABRICATED ITEM. For example, a 20 ft. length of aluminum which has been cut into 5 ft. (~152 cm) pieces by the Team for storage or transport is neither COTS (it's not in the state received from the VENDOR), nor a FABRICATED ITEM (the cuts were not made to advance the part towards its final form on the ROBOT).

Teams may be asked to provide documentation proving legality of non-2018 KOP items during Inspection where a Rule specifies limits for a legal part (e.g. pneumatic items, current limits, COTS electronics, etc.).

Some of these rules make use of English unit requirements for parts. If your team has a question about a metric-equivalent part's legality, please e-mail your question to [frcparts@firstinspires.org](mailto:frcparts@firstinspires.org) for an official ruling. To seek approval for alternate devices for inclusion in future *FIRST* Robotic Competition seasons, please contact [frcparts@firstinspires.org](mailto:frcparts@firstinspires.org) with item specifications.

Teams should acknowledge the support provided by the corporate Sponsors and Mentors with an appropriate display of their school and Sponsors names and/or logos (or the name of the supporting youth organization, if appropriate).

*FIRST* Robotics Competition can be a full-contact competition and may include rigorous game play. While the rules aim to limit severe damage to ROBOTS, Teams should design their ROBOTS to be robust.

## 8.2 General ROBOT Design

- R01.** The ROBOT (excluding BUMPERS) must have a FRAME PERIMETER, contained within the BUMPER ZONE, that is comprised of fixed, non-articulated structural elements of the ROBOT. Minor protrusions no greater than ¼ in. (~6.3 mm) such as bolt heads, fastener ends, weld beads, and rivets are not considered part of the FRAME PERIMETER.

To determine the FRAME PERIMETER, wrap a piece of string around the ROBOT (excluding BUMPERS) at the BUMPER ZONE described in R24 and pull it taut. The string outlines the FRAME PERIMETER.

Example: A ROBOT's chassis is shaped like the letter 'V', with a large gap between chassis elements on the front of the ROBOT. When wrapping a taut string around this chassis, the string extends across the gap and the resulting FRAME PERIMETER is a triangle with three sides.

Note: to permit a simplified definition of the FRAME PERIMETER and encourage a tight, robust connection between the BUMPERS and the FRAME PERIMETER, minor protrusions such as bolt heads, fastener

ends, rivets, etc. are excluded from the determination of the FRAME PERIMETER.

- R02.** In the STARTING CONFIGURATION (the physical configuration in which a ROBOT starts a MATCH), no part of the ROBOT shall extend outside the vertical projection of the FRAME PERIMETER, with the exception of its BUMPERS and minor protrusions such as bolt heads, fastener ends, rivets, cable ties, etc.

If a ROBOT is designed as intended and each side is pushed up against a vertical wall (in STARTING CONFIGURATION and with BUMPERS removed), only the FRAME PERIMETER (or minor protrusions) will be in contact with the wall.

The allowance for minor protrusions in R02 is intended to allow protrusions that are both minor in extension from the FRAME PERIMETER and cross sectional area.

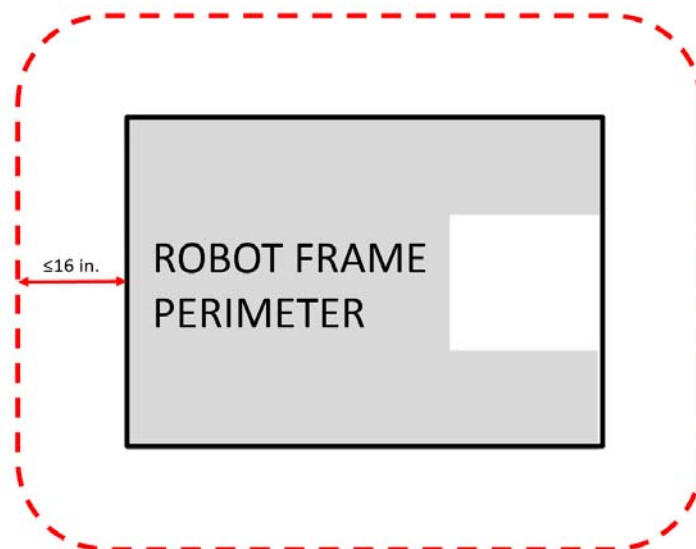
- R03.** In the STARTING CONFIGURATION, the maximum ROBOT size (excluding BUMPERS) must be constrained to a volume of 33 in. by 28 in. by 55 in. tall (~83 cm by ~71 cm by ~139 cm tall). Minor protrusions permitted in R01 and R02 (that are less than ¼ in. (~6.3 mm) such as bolt heads, fastener ends, weld beads, and rivets) are exempt from the 33 in. and 28 in. limits.

Expect to have to demonstrate a ROBOT'S ability to constrain itself per above during Inspection. Constraints may be implemented with either hardware or software.


Be sure to consider the size of the ROBOT on its cart to make sure it will fit through doors. Also consider the size of the ROBOT to ensure that it will fit into a shipping crate, bag, vehicle, etc.

- R04.** ROBOTS may not extend more than 16 in. (~40 cm) beyond their FRAME PERIMETER (see Figure 8-1), except during the ENDGAME (see G05).

Figure 8-1: FRAME PERIMETER Extension



- R05.** The ROBOT weight must not exceed 120 lbs. When determining weight, the basic ROBOT structure and all elements of all additional MECHANISMS that might be used in different configurations of the ROBOT shall be weighed together (see I03).



For the purposes of determining compliance with the weight limitations, the following items are excluded:

- A. ROBOT BUMPERS
- B. ROBOT battery and its associated half of the Anderson cable quick connect/disconnect pair (including no more than 12 in. (~30 cm) of cable per leg, the associated cable lugs, connecting bolts, and insulation)

### 8.3 ROBOT Safety & Damage Prevention

---

- R06. Traction devices must not have surface features such as metal, sandpaper, hard plastic studs, cleats, hook-loop fasteners or similar attachments that could damage the ARCADE. Traction devices include all parts of the ROBOT that are designed to transmit any propulsive and/or braking forces between the ROBOT and FIELD carpet.
- R07. Protrusions from the ROBOT and exposed surfaces on the ROBOT shall not pose hazards to the ARCADE elements (including the POWER CUBES) or people.

If the ROBOT includes protrusions that form the “leading edge” of the ROBOT as it drives and the protrusions have a surface area of less than 1 in.<sup>2</sup> (~6 cm<sup>2</sup>), it will invite detailed Inspection. For example, forklifts, lifting arms, or grapples may be carefully inspected for these hazards.

- R08. ROBOT parts shall not be made from hazardous materials, be unsafe, cause an unsafe condition, or interfere with the operation of other ROBOTS.

Examples of items that will violate R08 include (but are not limited to):

- A. Shields, curtains, or any other devices or materials designed or used to obstruct or limit the vision of any DRIVERS and/or COACHES and/or interfere with their ability to safely control their ROBOT
- B. Speakers, sirens, air horns, or other audio devices that generate sound at a level sufficient to be a distraction
- C. Any devices or decorations specifically intended to jam or interfere with the remote sensing capabilities of another ROBOT, including vision systems, acoustic range finders, sonars, infrared proximity detectors, etc. (e.g. including imagery on your ROBOT that, to a reasonably astute observer, mimics the retro-reflective features of vision targets described in [Section 3.9 Vision Targets](#))
- D. Exposed lasers other than Class I.
- E. Flammable gasses
- F. Any device intended to produce flames or pyrotechnics
- G. Hydraulic fluids or hydraulic items
- H. Switches or contacts containing liquid mercury
- I. Circuitry used to create voltages in excess of 24 Volts
- J. Any ballast not secured sufficiently, including loose ballast e.g. sand, ball bearings, etc., such that it may become loose during a MATCH.
- K. Exposed, untreated hazardous materials (e.g. lead weights) used on the ROBOT. These materials may be permitted if painted, encapsulated or otherwise sealed to prevent contact. These materials may not be machined in any way at an event.

- L. Tire sealant
- M. High intensity light sources used on the ROBOT (e.g. super bright LED sources marketed as 'military grade' or 'self-defense') may only be illuminated for a brief time while targeting and may need to be shrouded to prevent any exposure to participants. Complaints about the use of such light sources will be followed by re-inspection and possible disablement of the device.  
Teams should provide MSD Sheets for any materials they use that might be considered questionable during ROBOT Inspection.

- R09.** ROBOTS must allow removal of POWER CUBES from the ROBOT and the ROBOT from FIELD elements while DISABLED and powered off.

ROBOTS will not be re-enabled after the MATCH, so Teams must be sure that POWER CUBES and ROBOTS can be quickly, simply, and safely removed.

- R10.** Lubricants may be used only to reduce friction within the ROBOT. Lubricants must not contaminate the ARCADE or other ROBOTS.

## 8.4 Budget Constraints & Fabrication Schedule

---

- R11.** The total cost of all items on the ROBOT shall not exceed \$4000 USD. All costs are to be determined as explained in [Section 8.4 Budget Constraints & Fabrication Schedule](#). Exceptions are as follows:

- A. individual items that are less than \$5 USD each, as purchasable from a VENDOR, and
- B. KOP items

Teams should be prepared to disclose to Inspectors the cost of any non-KOP item and the total cost of the ROBOT.

Per I05, Teams must be prepared to display a Cost Accounting Worksheet (CAW) to Inspectors during Inspection. The CAW may be displayed in either printed or electronic form.

If the item is a KOP item, it does not need to be on the CAW.

Individual COMPONENTS or MECHANISMS, not excluded in R11, that are retrieved from previous ROBOTS and used on 2018 ROBOTS must have their undepreciated cost included in the 2018 CAW and applied to the overall cost assessment.

- R12.** No individual, non-KOP item shall have a value that exceeds \$500 USD. The total cost of COMPONENTS purchased in bulk may exceed \$500 USD as long as the cost of an individual COMPONENT does not exceed \$500 USD.

If a COTS item is part of a modular system that can be assembled in several possible configurations, then each individual module must fit within the price constraints defined in R12.

If the modules are designed to assemble into a single configuration, and the assembly is functional in only that configuration, then the total cost of the complete assembly including all modules must fit within the price constraints defined in R12.



In summary, if a VENDOR sells a system or a kit, a team must use the entire system/kit Fair Market Value and not the value of its COMPONENT pieces.

Example 1: VENDOR A sells a gearbox that can be used with a number of different gear sets, and can mate with two different motors they sell. A team purchases the gearbox, a gear set, and a motor (which are not offered together as an assembly or kit), then assembles them together. Each part is treated separately for the purpose of CAW costing, since the purchased pieces can each be used in various configurations.

Example 2: VENDOR B sells a robotic arm assembly that the team wants to use. However, it costs \$700 USD, so they cannot use it. The VENDOR sells the “hand”, “wrist”, and “arm” as separate assemblies, for \$200 USD each. A team wishes to purchase the three items separately, then reassemble them. This would not be legal, as they are really buying and using the entire assembly, which has a Fair Market Value of \$700 USD.

Example 3: VENDOR C sells a set of wheels or wheel modules that are often used in groups of four. The wheels or modules can be used in other quantities or configurations. A team purchases four and uses them in the most common configuration. Each part is treated separately for the purpose of CAW costing, since the purchased pieces can be used in various configurations.

- R13.** The CAW cost of each non-KOP item must be calculated based on the unit fair market value for the material and/or labor, except for labor provided by Team members (including sponsor employees who are members of the team), members of other Teams, event provided Machine Shops and shipping.

Example 1: A Team orders a custom bracket made by a company to the Team's specification. The company's material cost and normally charged labor rate apply.

Example 2: A Team receives a donated sensor. The company would normally sell this item for \$52 USD, which is therefore its fair market value.

Example 3: Special price discounts from National Instruments and other *FIRST* Suppliers are being offered to Teams. The discounted purchase price of items from these sources may be used in the additional parts accounting calculations.

Example 4: A Team purchases steel bar stock for \$10 USD and has it machined by a local machine shop. The machine shop is not considered a team Sponsor, but donates two (2) hours of expended labor anyway. The Team must include the estimated normal cost of the labor as if it were paid to the machine shop, and add it to the \$10 USD.

Example 5: A Team purchases steel bar stock for \$10 USD and has it machined by a local machine shop that is a recognized Sponsor of the Team. If the machinists are considered members of the Team, their labor costs do not apply. The total applicable cost for the part would be \$10 USD.

It is in the best interests of the Teams and *FIRST* to form relationships with as many organizations as possible. Teams are encouraged to be expansive in recruiting and including organizations in their team, as that exposes more people and organizations to *FIRST*. Recognizing supporting companies as Sponsors of, and members in, the Team is encouraged, even if the involvement of the Sponsor is solely through the donation of fabrication labor.

Example 6: A Team purchases steel bar stock for \$10 USD and has it machined by another Team. The total applicable cost for the part would be \$10 USD.

Example 7: A Team purchases a 4 ft. by 4 ft. (~122 cm by 122 cm) sheet of aluminum, but only uses a piece 10 in. by 10 in. (~25 cm by 25 cm) on their ROBOT. The Team identifies a source that sells aluminum sheet in 1 by 1 ft. pieces. The Team may cost their part on the basis of a 1 by 1 ft. piece, even though they cut the piece from a larger bulk purchase. They do not have to account for the entire 4 by 4 ft. bulk purchase item.

**R14.** Physical ROBOT elements created before Kickoff are not permitted. Exceptions are:

- A.** OPERATOR CONSOLE,
- B.** BUMPERS (a protective assembly designed to attach to the exterior of the ROBOT and constructed as specified in [Section 8.5 Bumper Rules](#)),
- C.** battery assemblies per R05-B,
- D.** FABRICATED ITEMS consisting of one COTS electrical device (e.g. a motor or motor controller) and attached components associated with any of the following modifications:
  - i.** Wires modified to facilitate connection to a ROBOT (including removal of existing connectors)
  - ii.** Connectors and any materials to secure and insulate those connectors added
  - iii.** Motor shafts modified and/or gears, pulleys, or sprockets added

Please note that this means that FABRICATED ITEMS from ROBOTS entered in previous *FIRST* competitions may not be used on ROBOTS in the 2018 *FIRST*® Robotics Competition (other than those allowed per R14-B through R14-D). Before the formal start of the Build Season, Teams are encouraged to think as much as they please about their ROBOTS. They may develop prototypes, create proof-of-concept models, and conduct design exercises. Teams may gather all the raw stock materials and COTS COMPONENTS they want.

Example 1: A Team designs and builds a two-speed shifting transmission during the fall as a training exercise. After Kickoff, they utilize all the design principles they learned in the fall to design their ROBOT. To optimize the transmission design for their ROBOT, they improve the transmission gear ratios and reduce the size, and build two new transmissions, and place them on the ROBOT. All parts of this process are permitted activities.

Example 2: A Team re-uses a 2018-legal motor from a previous ROBOT which has had connectors added to the wires. This is permitted, per exception D, because the motor is a COTS electrical COMPONENT.





- R15.** Software and mechanical/electrical designs created before Kickoff are only permitted if the source files (complete information sufficient to produce the design) are available publicly prior to Kickoff.

Example 1: A Team realizes that the transmission designed and built in the fall perfectly fits their need for a transmission to drive the ROBOT arm. They build an exact copy of the transmission from the original design plans, and bolt it to the ROBOT. This would be prohibited, as the transmission – although made during the competition season – was built from detailed designs developed prior to Kickoff.

Example 2: A Team developed an omni-directional drive system for the 2011 competition. Over the summer of 2011 they refined and improved the control software (written in C++) to add more precision and capabilities. They decided to use a similar system for the 2018 competition. They copied large sections of unmodified code over into the control software of the new ROBOT (also written in C++). This would be a violation of the schedule constraint, and would not be allowed.

Example 3: The same Team decides to use LabVIEW as their software environment for 2018. Following Kickoff, they use the previously-developed C++ code as a reference for the algorithms and calculations required to implement their omni-directional control solution. Because they developed new LabVIEW code as they ported over their algorithms, this would be permitted.

Example 4: A different Team develops a similar solution during the fall, and plans to use the developed software on their competition ROBOT. After completing the software, they post it in a generally accessible public forum and make the code available to all Teams. Because they have made their software publicly available before Kickoff, they can use it on their ROBOT.

Example 5: A Team develops a transmission during the fall. After completing the project, they publish the CAD files on a generally accessible public forum and make them available to all Teams. Because they have made the design publicly available before Kickoff, they can use the design to create an identical transmission, fabricated after Kickoff, for use on their 2018 ROBOT.

- R16.** All ROBOT elements (including items intended for use during the competition in alternative configurations of the ROBOT), with the exception of the WITHHOLDING ALLOWANCE per R22, BUMPERS, and COTS items, must be bagged and sealed, by 04:59 UTC on Stop Build Day, Wednesday, February 21, 2018.

PLEASE NOTE: THIS TIME IS DICTATED IN UTC (UNIVERSAL COORDINATED TIME). YOU WILL NEED TO CONVERT TO YOUR LOCAL TIMEZONE. THIS WILL RESULT IN A TIME ON THE PREVIOUS DAY (TUESDAY, FEBRUARY 20, 2018) FOR MANY TIMEZONES.

To bag your ROBOT:

- Locate the “Bag and Tag” kit from your Kickoff Kit which contains two plastic bags large enough to contain your ROBOT and at least ten tags with individual serial numbers.
- Set the bag on the floor, leaving room for the ROBOT in the center.

- Place the ROBOT in the center of the bag and pull the bag up around the ROBOT. Be careful not to catch the bag on the corners or sharp edges.
- Tightly seal the bag with your next numbered tag.
- Complete the ROBOT Lock-up Form to verify the date and time that the bag was sealed. The ROBOT Lock-up Form must be signed by an adult, 18 years old or older, who is not a student on the team. This form must be brought with you to all events.

**R17.** For convenience, Teams may disassemble their ROBOT and use up to three (3) bags to “Bag and Tag” the pieces. Each bag must have its own numbered tag and entry on the ROBOT Lock-up Form.

Note: The KOP only contains two (2) bags. Teams wishing to use three (3) bags must acquire the third bag themselves.

When transporting their ROBOT, Teams may use any transportation method they wish (at their own risk and expense), as long as the ROBOT remains sealed in the bag.

**R18.** If you are attending another event, such as a *FIRST* Championship or another Regional or District event, you must re-seal your ROBOT in the bag with a new tag and enter the new tag number on the ROBOT Lock-up Form prior to leaving the event.

**R19.** Teams must stay “hands-off” their bagged ROBOT elements during the following time periods:

- between Stop Build Day and their first event,
- during the period(s) between their events, and
- outside of Pit hours while attending events.

Modifying parts at night offsite (e.g. pits have closed and you bring a MECHANISM back to the hotel to fix it) is a violation of R19-C.

Additional time is allowed as follows:

- After Kickoff, there are no restrictions on when software may be developed.
- On days a team is not attending an event, they may continue development of any items permitted per R22, including items listed as exempt from R22, but must do so without interfacing with the ROBOT.
- ROBOTS may be unbagged for unofficial pre-inspection, with a certified 2018 LRI present. No work on or operation of the ROBOT is permitted beyond what is necessary to emulate the Inspection process. The purpose of this unofficial pre-inspection is to identify, in advance, potential issues with the ROBOT that may be found during the official inspection that takes place at the event. The ROBOT Lock-up Form must be used to track the unbagging and rebagging of the ROBOT during this period. In the “Explanation” column of the form, enter “LRI Pre-Inspection.”
- ROBOTS may be unbagged and operated briefly after “Stop Build Day” for brief display purposes only, or for any other purpose that could be reasonably considered ‘display only’ provided the following requirements are met:
  - The ROBOT Lock-up Form must be used to track the unbagging and rebagging of the ROBOT during this period. In the “Explanation” column of the form, enter “Robot Display”.



- ii. No activity that could be considered “work on” or “practice with” the ROBOT is allowed.
- iii. Brief displays of robot functions, driving for example, are allowed, but not to the extent that they could be considered practice

The intent of this option is to allow Teams to briefly show off their ROBOT (e.g. to their community, sponsors, judges, or potential sponsors) after “Stop Build Day”. The intent is not to allow ‘exhibition matches’, or other similar activities, as this would be considered practice.

Unbagging a ROBOT and putting it on display for many hours (i.e., more than four (4)) at a time is not considered a “brief” display.

A good way to avoid turning a ROBOT display period in to a practice session is to have non-DRIVE TEAM members operate the ROBOT, and only for as short a time as necessary to show the ROBOT’S capabilities.

If you have any questions about the ROBOT Display option, please email [frcparts@firstinspires.org](mailto:frcparts@firstinspires.org).

- H. Teams attending 2-day events may access their ROBOTS using the ROBOT Access Period.

Teams attending 2-day events will not have as much time to work on their ROBOTS at events as Teams attending traditional 3-day Regional events. Due to this, teams are granted an additional “Robot Access Period” to un-bag their ROBOT between the “Stop Build Day” and their 2-day district events. 2-day events for the 2018 season include District Qualifier events for the following areas:

- *FIRST* Chesapeake District (DC, MD, VA)
- *FIRST* Israel District (IS)
- *FIRST* Mid-Atlantic District (DE, NJ, Eastern PA)
- *FIRST* North Carolina District (NC)
- *FIRST* in Michigan District (MI)
- Ontario District (ON)
- Indiana *FIRST* District (IN)
- NE *FIRST* District (CT, MA, ME, NH, RI, VT)
- Pacific Northwest (AK, OR, WA)
- Peachtree District (GA)

- R20. Teams permitted to use the ROBOT Access Period per R19-H may only unlock their ROBOT for a total of six (6) hours during the 7-day period preceding any 2-day event in which their Team will be competing with their ROBOT.

The six hours may be broken up in any way the team wishes, with the exception that no single access period may be shorter than two (2) hours.

The ROBOT must be locked up between sessions which must be documented on the ROBOT Lock-up Form.

- R21. If the ROBOT is accessed before the event, the unbagging must be noted on the ROBOT Lock-up form and the ROBOT must be rebagged. The ROBOT must remain sealed in the bag until:



- A. Your ROBOT Lock-up Form has been checked and approved by an Inspector and
- B. The pits have officially been opened for ROBOT work.

**R22.** At each Event, Teams may have access to a WITHHOLDING ALLOWANCE. The WITHHOLDING ALLOWANCE is a static set of FABRICATED ITEMS that shall not exceed 30 lbs. (~13 kg.), brought to an event (or ROBOT Access Period) in addition to the bagged items, to be used to repair and/or upgrade their ROBOT. With permission from another Team, Teams may also have access to FABRICATED ITEMS that are part of that other Team's WITHHOLDING ALLOWANCE to repair and/or upgrade their ROBOT. The WITHHOLDING ALLOWANCE may only be brought into the Venue when the Team initially loads in at the Event. Items made at an Event do not count towards this weight limit.

Teams should be prepared to show their WITHHOLDING ALLOWANCE items, and potentially have them weighed, during load-in.

This means teams may not store FABRICATED ITEMS outside the pits to be brought to the event at a later time. This set may be changed between events (i.e. a Team may leave a different set of items out of the bag and/or fabricate new items to bring to their next event) provided the total weight of FABRICATED ITEMS brought to the next event does not exceed thirty (30) lbs. (~13 kg.).

There is no restriction on the quantity of COTS items or items which do not meet the definitions of COTS or FABRICATED ITEMS (e.g. raw materials) that may be accessed by a Team at an Event.

For Teams attending 2-Day Events, these FABRICATED ITEMS may be used during the ROBOT Access Period and/or brought to the Event, but the total weight may not exceed 30 lbs. (~13 kg.) FABRICATED ITEMS constructed during the ROBOT Access Period and bagged with the ROBOT are exempt from this limit.

Items specified as exempt from R14 are also exempt from the WITHHOLDING ALLOWANCE limit.

Example 1: A team creates 10 lbs (~4 kg.) of FABRICATED ITEMS after Stop Build Day. During their first ROBOT Access Period before their first event, they install these items on the ROBOT and bag them with the ROBOT. The team may bring up to 20 lbs. (~9 kg.) of FABRICATED ITEMS (which may be items removed from the ROBOT before bagging at the end of the ROBOT Access Period) with them to the event.

Example 2: A team creates 30 lbs (~13 kg.) of FABRICATED ITEMS after Stop Build Day. During their first ROBOT Access Period before their first event, they install these items on the ROBOT and bag them with the ROBOT. The team may not bring any FABRICATED ITEMS (including any initially bagged on Stop Build Day and removed during the ROBOT Access Period) with them to the event.

## 8.5 BUMPER Rules

---

A BUMPER is a required assembly which attaches to the ROBOT frame. BUMPERS are important because they protect ROBOTS from damaging/being damaged by other ROBOTS and FIELD elements. Criteria used in writing these rules included the following:

- Minimize variety of BUMPERS so teams can expect consistency
- Minimize the amount of design challenge in creating BUMPERS
- Minimize cost of BUMPER materials



- Maximize use of relatively ubiquitous materials

**R23.** ROBOTS are required to use BUMPERS to protect all outside corners of the FRAME PERIMETER. For adequate protection, at least 6 in. (~16 cm) of BUMPER must be placed on each side of each outside corner (see Figure 8-2) and must extend to within  $\frac{1}{4}$  in. of the FRAME PERIMETER corner. If a FRAME PERIMETER side is shorter than 6 in. (~16 cm), that entire side must be protected by BUMPER (see Figure 8-3). A round or circular FRAME PERIMETER, or segment of the FRAME PERIMETER, is considered to have an infinite number of corners, therefore the entire frame or frame segment must be completely protected by BUMPER(S).

The dimension defined in R23 is measured along the FRAME PERIMETER. The portion of the BUMPER that extends beyond the corner of the FRAME PERIMETER is not included in the 6 in. (~16 cm) requirement. See Figure 8-2 below.



Figure 8-2: BUMPER corner examples

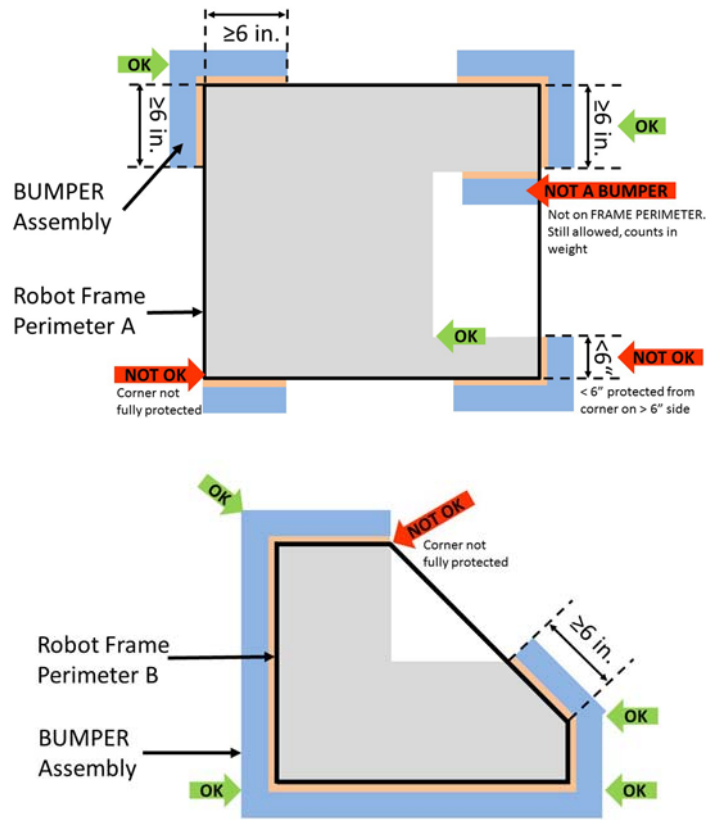
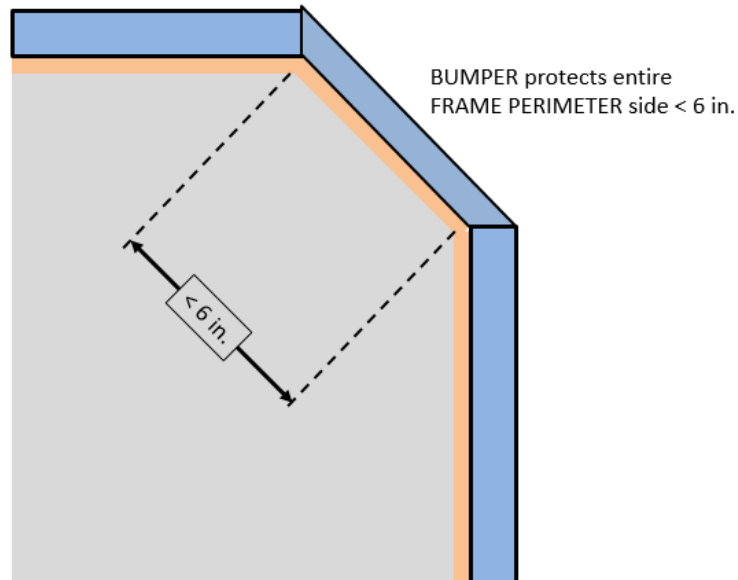


Figure 8-3: BUMPER around full side/corner.



**R24.** BUMPERS must be located entirely within the BUMPER ZONE, which is the volume contained between the floor and a virtual horizontal plane 7½ in. (~19 cm) above the floor in reference to the ROBOT standing normally on a flat floor. BUMPERS do not have to be parallel to the floor.



This measurement is intended to be made as if the ROBOT is resting on a flat floor (without changing the ROBOT configuration), not relative to the height of the ROBOT from the FIELD carpet. Examples include:

Example 1: A ROBOT that is at an angle while navigating the FIELD has its BUMPERS outside the BUMPER ZONE. If this ROBOT were virtually transposed onto a flat floor, and its BUMPERS are in the BUMPER ZONE, it meets the requirements of R24.

Example 2: A ROBOT deploys a MECHANISM which lifts the BUMPERS outside the BUMPER ZONE (when virtually transposed onto a flat floor). This violates R24.

- R25. BUMPERS must not be articulated (relative to the FRAME PERIMETER).
- R26. BUMPERS (the entire BUMPER, not just the cover) must be designed for quick and easy installation and removal to facilitate inspection and weighing.

As a guideline, BUMPERS should be able to be installed or removed by two (2) people in fewer than five (5) minutes.

- R27. Each ROBOT must be able to display Red or Blue BUMPERS to MATCH their ALLIANCE color, as assigned in the MATCH schedule distributed at the event (as described in [Section 10.1 MATCH Schedules](#)). BUMPER Markings visible when installed on the ROBOT, other than the following, are prohibited:
  - A. those required per R28,
  - B. hook-and-loop fastener or snap fasteners backed by the hard parts of the BUMPER, and
  - C. solid white *FIRST* logos between 4¼ in. (~13 cm) and 5¼ in. wide (~13 cm) (i.e. comparable to those distributed in the 2017 Kickoff Kit) and available in 2018 *FIRST* Choice.
- R28. Team numbers must be displayed and positioned on the BUMPERS such that an observer walking around the perimeter of the ROBOT can unambiguously tell the Team's number from any point of view and meet the following additional criteria:
  - A. consist of Arabic numerals at least 4 in. (~11 cm) high, at least ½ in. (~12.7 mm) in stroke width, and be either white in color or outlined in white with a minimum 1/16 in. (~1.6mm) outline

The ½ in. stroke width requirement applies to the majority of the stroke. Font elements less than ½ in. such as serifs, rounded edges, small hairlines or gaps, etc. are permitted as long as the majority of the stroke meets the sizing requirement and the numbers are unambiguous.

- B. must not wrap around sharp corners (less than 160 degrees) of the FRAME PERIMETER
- C. may not substitute logos or icons for numerals

There is no prohibition against splitting Team numbers onto different sections of BUMPER. The intent is that the Team's number is clearly visible and unambiguous so that Judges, REFEREES, Announcers, and other Teams can easily identify competing ROBOTS.

This marking is intended to display the Team number only, not to intentionally change the surface characteristics of the BUMPER.

Excessive material usage as part of any Team number marking will invite close scrutiny.

- R29.** Each set of BUMPERS (including any fasteners and/or structures that attach them to the ROBOT) must weigh no more than 20 lbs (~9 kg).

If a multi-part attachment system is utilized (e.g. interlocking brackets on the ROBOT and the BUMPER), then the elements permanently attached to the ROBOT will be considered part of the ROBOT, and the elements attached to the BUMPERS will be considered part of the BUMPER. Each element must satisfy all applicable rules for the relevant system.

- R30.** BUMPERS must be constructed as follows (see Figure 8-6):

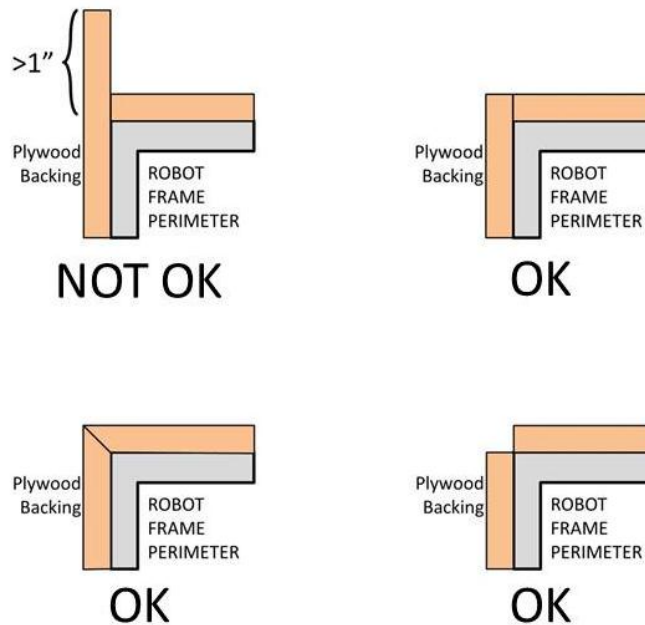
- A.** be backed by  $\frac{3}{4}$  in. (nominal) thick (~19mm) by 5 in.  $\pm$   $\frac{1}{2}$  in. (~127 mm  $\pm$  12.7 mm) tall plywood or solid, robust wood. Small clearance pockets and/or access holes in the plywood backing are permitted, as long as they do not significantly affect the structural integrity of the BUMPER.

Particle board or chipboard is not likely to survive the rigors of *FIRST* Robotics Competition gameplay and thus not compliant with R30-A.

Note:  $\frac{3}{4}$ " plywood is now often marked according to the actual dimension ( $\frac{23}{32}$ " ) not the nominal size. Plywood sold as  $\frac{23}{32}$ " meets the requirements of R30-A.

- B.** hard BUMPER parts allowed per R30-A, R30-E, R30-F, and R30-G must not extend more than 1 in. (~25 mm) beyond the FRAME PERIMETER with the exception of minor protrusions such as bolt heads, fastener ends, rivets, etc. (Figure 8-4 and Figure 8-6).

Figure 8-4: Hard Parts of BUMPER Corners



- C.** use a stacked pair of approximately 2½ in. (nominal) round, petal, or hex “pool noodles” (solid or hollow) as the BUMPER cushion material (see Figure 8-6). All pool noodles used in a BUMPER set (e.g. Red set of BUMPERS) may not be deformed

and must be the same diameter, cross-section, and density (e.g. all round hollow or all hex solid). Cushion material may extend up to 2½ in. (~63 mm) beyond the end of the plywood (see Figure 8-7). To assist in applying the fabric covering, soft fasteners may be used to attach the pool noodles to the wood backing, so long as the cross section in Figure 8-6 is not significantly altered (e.g. tape compressing the pool noodles).

All pool noodles used on a ROBOT must be the same in order to maintain the desired interaction between ROBOTS in the cases of BUMPER-to-BUMPER contact. BUMPERS containing pool noodles of vastly different construction may cause a “ramp” effect when interacting with other BUMPERS.

Noodle compression as a result of smoothing BUMPER fabric is not considered deformed. Any compression beyond that, e.g. for the purposes of flattening the noodle, is deformation and a violation of R30-C.

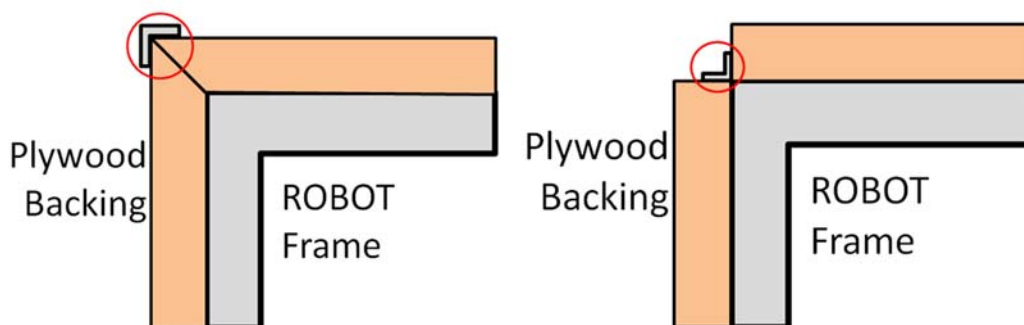
- D. be covered with a rugged, smooth cloth. (multiple layers of cloth and seams are permitted if needed to accommodate R27, provided the cross section in Figure 8-6 is not significantly altered).

Silk and bedding are not considered rugged cloths, however 1000D Cordura is. Tape (e.g. gaffer’s tape) matching the BUMPER color is allowed to patch small holes on a temporary basis.

The cloth must completely enclose all exterior surfaces of the wood and pool noodle material when the BUMPER is installed on the ROBOT. The fabric covering the BUMPERS must be solid in color.

- E. optionally use aluminum angle, as shown in Figure 8-6 or other fasteners (e.g. staples, screws, etc.) to clamp cloth.
- F. optionally use aluminum brackets (i.e. angle or sheet metal) to attach BUMPER segments to each other (see Figure 8-5).

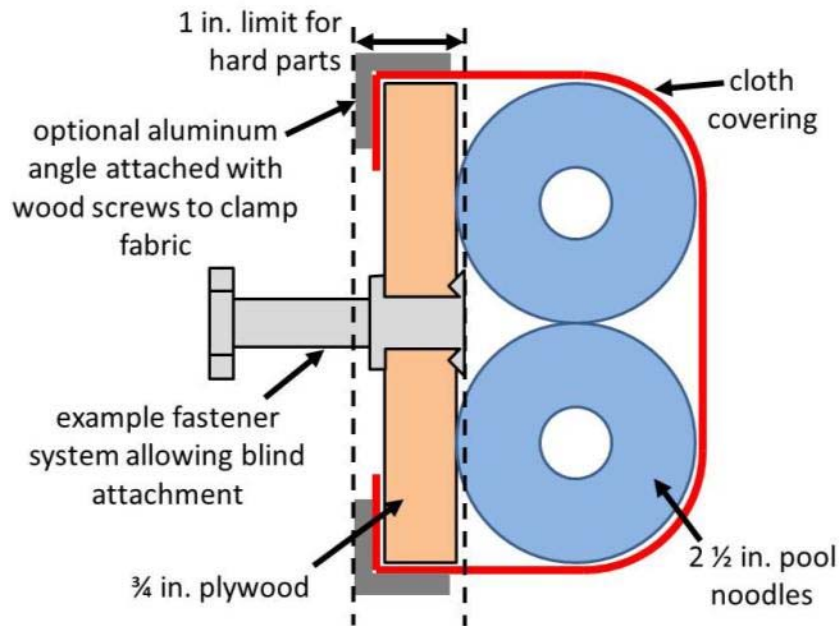
Figure 8-5: Hard Parts of BUMPER Corners



- G. must attach to the FRAME PERIMETER of the ROBOT with a rigid fastening system to form a tight, robust connection to the main structure/frame (e.g. not attached with hook-and-loop, tape, or tie-wraps). The attachment system must be designed to withstand vigorous game play. All removable fasteners (e.g. bolts, locking pins, pip-pins, etc.) will be considered part of the BUMPERS.

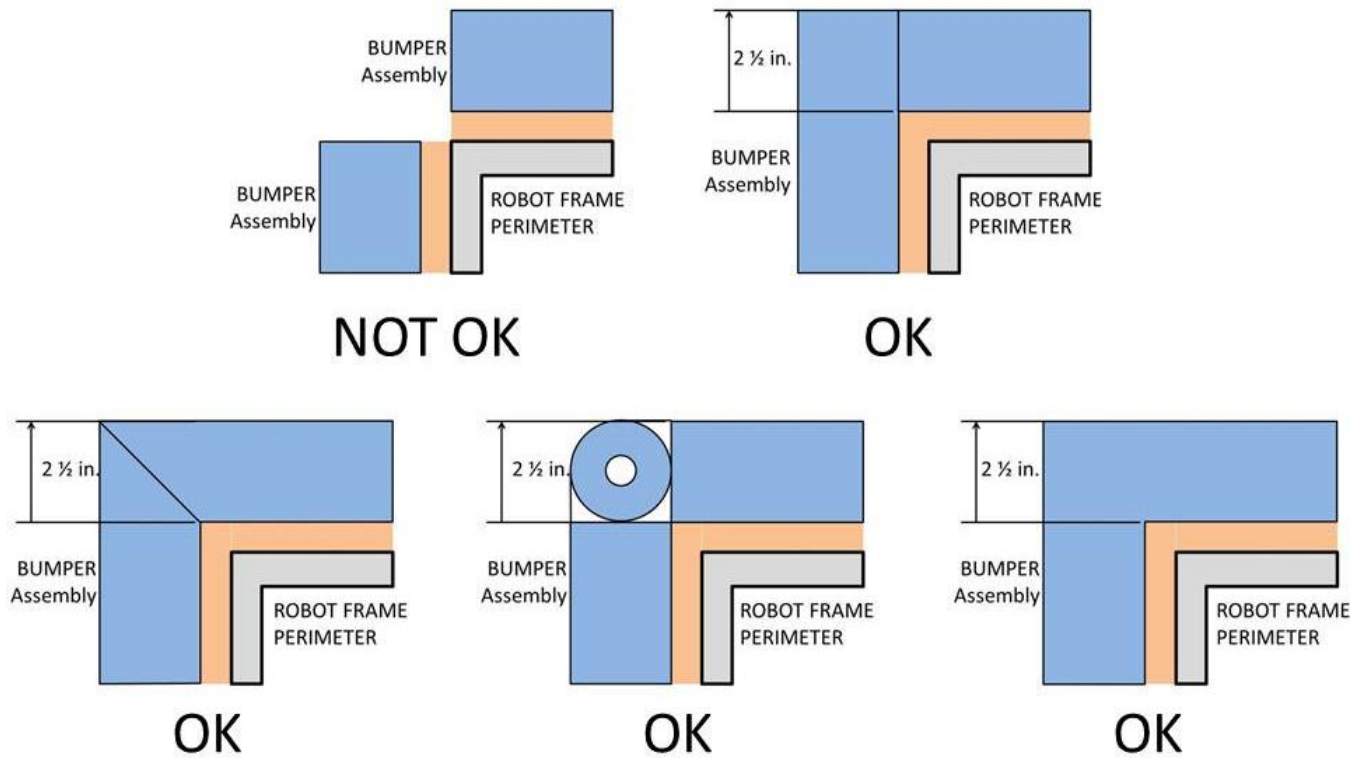


Figure 8-6: BUMPER Vertical Cross Section



- R31.** Corner joints between BUMPERS must be filled with pool noodle material. Examples of implementation are shown in Figure 8-7.

Figure 8-7: Soft Parts of BUMPER Corners



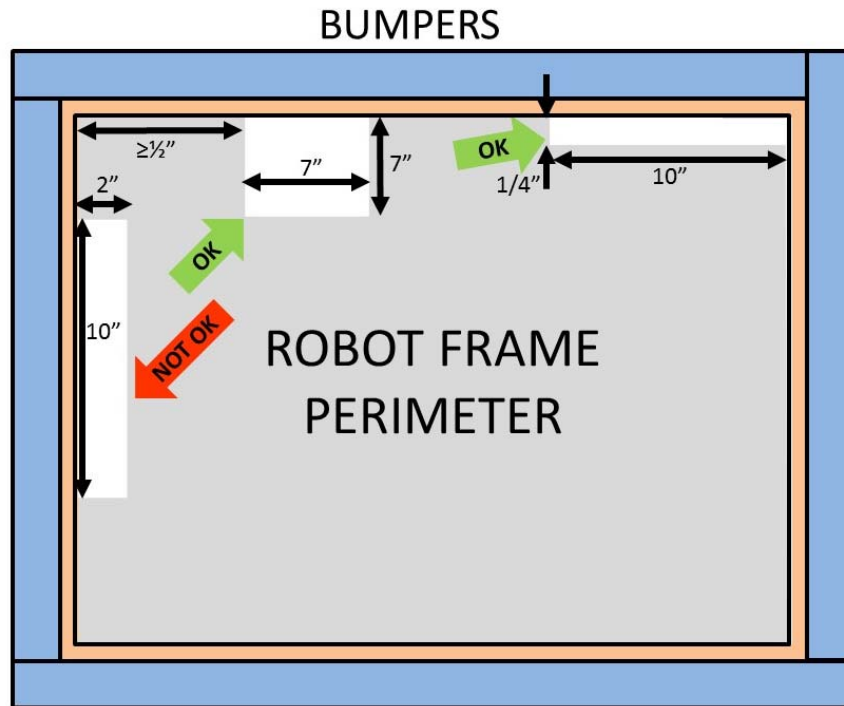
- R32.** BUMPERS must be supported by the structure/frame of the ROBOT (see Figure 8-8). To be considered supported, a minimum of 1/2 in. (~12.7 mm) at each end of each BUMPER wood



segment must be backed by the FRAME PERIMETER ( $\leq 1/4$  in. gap). “Ends” exclude hard BUMPER parts which extend past the FRAME PERIMETER permitted by R30, part B. Additionally, any gap between the backing material and the frame:

- A. must not be greater than  $1/4$  in. (~6 mm) deep, or
- B. not more than 8 in. (~20 cm) wide

Figure 8-8: BUMPER support examples



## 8.6 Motors & Actuators

- R33. The only motors and actuators permitted on 2018 ROBOTS include the following (in any quantity):

Table 8-1: Motor allowances

Motor Name	Part Numbers Available
CIM	FR801-001
	M4-R0062-12
	AM802-001A
	217-2000
	PM25R-44F-1005
	PM25R-45F-1004
	PM25R-45F-1003
	PMR25R-45F-1003
	PMR25R-44F-1005
	am-0255
West Coast Products RS775 Pro	217-4347
Banebots	M7-RS775-18
	RS775WC-8514
	M5 – RS550-12
	RS550VC-7527
	RS550
AndyMark 9015	am-0912
VEX BAG	217-3351
VEX mini-CIM	217-3371
AndyMark PG	am-2161 (alt. PN am-2765) am-2194 (alt. PN am-2766)
Select Automotive Motors (Window, Door, Windshield wiper, Seat, Throttle)	Various
Snow Blower Motor	am-2235
AndyMark NeveRest	am-3104
AndyMark RedLine Motor	am-3775
Nidec Dynamo BLDC Motor	am-3740 DM3012-1063
Electrical solenoid actuators, no greater than 1 in. (nominal) stroke and rated electrical input power no greater than 10 watts (W) continuous duty at 12 volts (VDC)	
Hard drive motors or fans that are: included in any Kickoff Kit, distributed via FIRST Choice, part of a legal motor controller (including manufacturer provided accessories), or part of a legal COTS computing device	
Factory installed vibration and autofocus motors resident in COTS computing devices (e.g. rumble motor in a smartphone).	
PWM COTS servos with a retail cost < \$75.	
Motors integral to a COTS sensor (e.g. LIDAR, scanning sonar, etc.), provided the device is not modified except to facilitate mounting	

For servos, note that the roboRIO is limited to a max current output of 2.2A on the 6V rail (12.4W of electrical input power). Teams should make sure that their total servo power usage remains below this limit at all times.

Given the extensive amount of motors allowed on the ROBOT, Teams are encouraged to consider the total power available from the ROBOT



battery during the design and build of the ROBOT. Drawing large amounts of current from many motors at the same time could lead to drops in ROBOT battery voltage that may result in tripping the main breaker or trigger the brownout protection of the roboRIO. For more information about the roboRIO brownout protection and measuring current draw using the PDP, see [roboRIO Brownout and Understanding Current Draw](#).

- R34.** The integral mechanical and electrical system of any motor must not be modified. Motors, servos, and electric solenoids used on the ROBOT shall not be modified in any way, except as follows:
- A.** The mounting brackets and/or output shaft/interface may be modified to facilitate the physical connection of the motor to the ROBOT and actuated part.
  - B.** The electrical input leads may be trimmed to length as necessary and connectors or splices to additional wiring may be added.
  - C.** The locking pins on the window motors (P/N: 262100-3030 and 262100-3040) may be removed.
  - D.** The connector housings on window, door, windshield wiper or seat motors and Bosch motors (P/N: 6004 RA3 353-01) may be modified to facilitate lead connections.
  - E.** Servos may be modified as specified by the manufacturer (e.g. re-programming or modification for continuous rotation).
  - F.** The wiring harness of the Nidec Dynamo BLDC Motor may be modified [as documented by FIRST in the "Nidec Dynamo BLDC Motor with Controller" Screensteps article](#).

The intent of this rule is to allow teams to modify mounting tabs and the like, not to gain a weight reduction by potentially compromising the structural integrity of any motor. The integral mechanical and electrical system of the motor is not to be modified.

Note that for the previous KOP Window motors and the Bosch motor, the gearbox is considered integral to the motor, thus the motor may not be used without the gearbox.

- R35.** With the exception of servos, fans, or motors integral to sensors of COTS computing devices permitted in R33, each actuator must be controlled by a power regulating device. The only power regulating devices for actuators permitted on the ROBOT include:
- A.** Motor Controllers
    - i.** DMC 60 Motor Controller (P/N: 410-334-1)
    - ii.** Nidec Dynamo BLDC Motor with Controller to control integral actuator only (P/N 840205-000, am-3740)
    - iii.** Jaguar Motor Controller (P/N: MDL-BDC, MDL-BDC24, and 217-3367) connected to PWM only
    - iv.** SD540 Motor Controller (P/N: SD540x1, SD540x2, SD540x4, SD540Bx1, SD540Bx2, SD540Bx4, SD540C)
    - v.** Spark Motor Controller (P/N: REV-11-1200)
    - vi.** Talon Motor Controller (P/N: CTRE\_Talon, CTRE\_Talon\_SR, and am-2195)
    - vii.** Talon SRX Motor Controller (P/N: 217-8080, am-2854, 14-838288)
    - viii.** Victor 884 Motor Controller (P/N: VICTOR-884-12/12)



- ix. Victor 888 Motor Controller (P/N: 217-2769)
- x. Victor SP Motor Controller (P/N: 217-9090, am-2855, 14-868380)
- xi. Victor SPX Motor Controller (P/N: 217-9191, 17-868388, am-3748)

**B. Relay Modules**

- i. Spike H-Bridge Relay (P/N: 217-0220 and SPIKE-RELAY-H)

**C. Pneumatics controllers**

- i. Pneumatics Control Module (P/N: am-2858, 217-4243)

**R36.** Each power regulating device may control electrical loads per Table 8-2. Unless otherwise noted, each power regulating device shall control one and only one electrical load.

*Table 8-2: Power regulating device allotments*

Electrical Load	Motor Controller	Relay Module	Pneumatics Controller
CIM AndyMark 9015 WCP RS775 Pro VEX BAG/MiniCIM Banebots AndyMark RedLine Motor	Yes	No	No
Automotive Window/Door/Windshield Wiper/Seat/Throttle Motors AndyMark PG Snow-Blower Motor NeverRest	Yes (up to 2 per controller)	Yes	No
Nidec Dynamo BLDC Motor with Controller	Yes (integrated controller only)	No	No
Compressor	No	Yes	Yes
Pneumatic Solenoid Valves	No	Yes <sup>1</sup>	Yes (1 per channel)
Electric Solenoids	No	Yes <sup>1</sup>	Yes (1 per channel)
CUSTOM CIRCUITS <sup>2</sup>	Yes	Yes <sup>1</sup>	Yes (1 per channel)

<sup>1</sup> Multiple low-load, pneumatic solenoid valves, electric solenoids or CUSTOM CIRCUITS may be connected to a single relay module. This would allow one (1) relay module to drive multiple pneumatic actions or multiple CUSTOM CIRCUITS. No other electrical load can be connected to a relay module used in this manner.

<sup>2</sup> A CUSTOM CIRCUIT is any electrical COMPONENT of the ROBOT other than motors, pneumatic solenoids, roboRIO, PDP, PCM, VRM, RSL, 120A breaker, motor controllers, relay modules (per R35-B), wireless bridge, or batteries.

**R37.** Servos must be connected to, and only to, one of the following:

- A. PWM ports on the roboRIO
- B. PWM ports on a WCP Spartan Sensor Board (P/N: WCP-0045)

- C. REV Servo Power Module (P/N: REV-11-1144)

## 8.7 Power Distribution

---

- R38.** The only legal source of electrical energy for the ROBOT during the competition, the ROBOT battery, must be a non-spillable sealed lead acid (SLA) battery with the following specifications:
- A. Nominal voltage: 12V
  - B. Nominal capacity at 20-hour discharge rate: minimum 17Ah, maximum 18.2Ah
  - C. Shape: Rectangular
  - D. Nominal Dimensions: 7.1 in. x 3 in. x 6.6 in., +/- .1 in. for each dimension (~ 180 mm x 76mm x 168 mm, +/- 2.5 mm for each dimension)
  - E. Nominal weight: 11lbs. to 14.5 lbs. (~5 kg. to 6.5 kg.)
  - F. Terminals: Nut and bolt style

Examples of batteries which meet these criteria include:

- A. Energysys (P/N: NP18-12, NP18-12B, NP18-12BFR)
- B. MK Battery (P/N: ES17-12)
- C. Battery Mart (P/N: SLA-12V18)
- D. Sigma (P/N: SP12-18)
- E. Universal Battery (P/N: UB12180)
- F. Power Patrol (P/N: SLA1116)
- G. Werker Battery (P/N: WKA12-18NB)
- H. Power Sonic (P/N: PS-12180NB)
- I. Yuasa (P/N: NP18-12B)
- J. Panasonic (P/N: LC-RD-1217)
- K. Interstate Batteries (P/N: BSL1116)
- L. Duracell Ultra Battery (P/N: DURA12-18NB)

Teams should be aware that they may be asked to provide documentation of the specifications of any battery not listed above.

Batteries should be charged in accordance with manufacturer's specification. (Please see the [FIRST Safety Manual](#) for additional information.)

- R39.** COTS USB battery packs with a capacity of 100Wh or less (20000mAh at 5V) and 2.5 Amp max output per port, or batteries integral to and part of a COTS computing device or self-contained camera (e.g. laptop batteries, GoPro style camera, etc.) may be used to power COTS computing devices and any peripheral COTS input or output devices connected to the COTS computing device provided they are:
- A. securely fastened to the ROBOT.
  - B. connected only using unmodified COTS cables
  - C. charged according to manufacturer recommendations

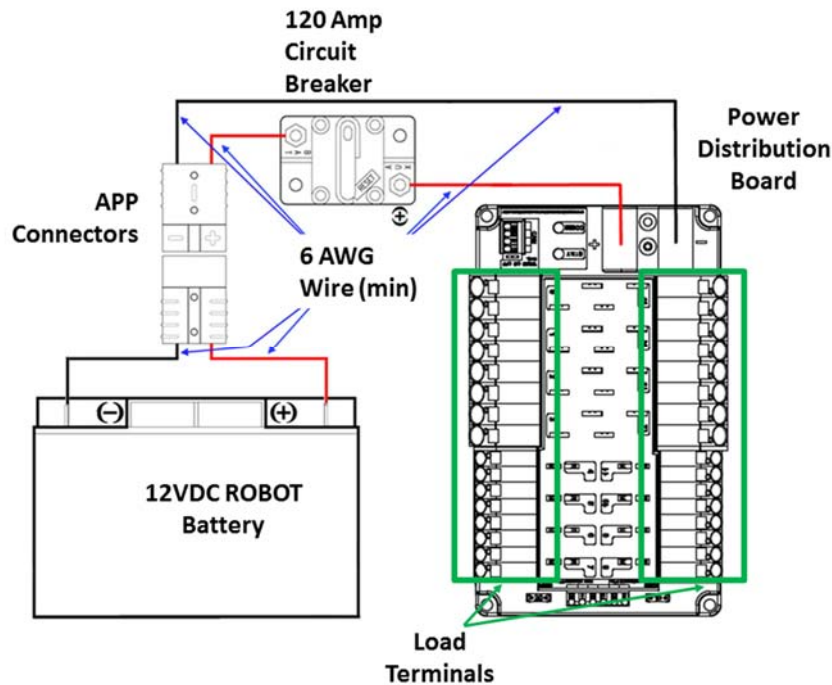


- R40.** Any battery charger used to charge a ROBOT battery must have the corresponding Anderson SB connector installed.
- R41.** Any battery charger used to charge a ROBOT battery may not be used such that it exceeds 6-Amp peak charge current.
- R42.** No batteries other than those allowed per R38 and R39 are allowed on the ROBOT, whether or not they are being used to supply power.

This means teams may not use additional batteries as extra weight on their ROBOTS, for example.

- R43.** The ROBOT battery must be secured such that it will not dislodge during vigorous ROBOT interaction including if the ROBOT is turned over or placed in any arbitrary orientation.
- R44.** Each electrical terminal on the ROBOT battery, main breaker, and their connections (lugs, stripped wire ends, etc.) to the wire must be fully insulated at all times.
- R45.** Non-electrical sources of energy used by the ROBOT, (i.e., stored at the start of a MATCH), shall come only from the following sources:
  - A.** compressed air stored in the pneumatic system that has been charged in compliance with R85 and R87,
  - B.** a change in the altitude of the ROBOT center of gravity,
  - C.** storage achieved by deformation of ROBOT parts,
  - D.** closed-loop COTS pneumatic (gas) shocks, and
  - E.** air-filled (pneumatic) wheels.
- R46.** The one (1) ROBOT battery, a single pair of Anderson Power Products (or APP) 2-pole SB type connectors, the one (1) main 120-amp (120A) surface mount circuit breaker (Cooper Bussman P/N: CB185-120 or CB185F-120), and the one (1) CTR Electronics Power Distribution Panel (PDP, P/N: am-2856, 217-4244, 14-806880) shall be connected with 6 AWG (7 SWG or 16 mm<sup>2</sup>) copper wire or larger, with no additional devices or modifications, as shown in Figure 8-9.

Figure 8-9: Electrical connection diagram



“SB type” refers to SB type only (e.g. SB-50, SB-120, etc.), not SBS or any other part type beginning with SB. All batteries supplied by *FIRST* (such as Spare Parts and international batteries) will have a Red or Pink SB50 connector installed which may not be removed.

The pink connectors included in the 2018 KOP mate with the Red SB50 connector.

- R47. All circuits, with the exceptions of those listed in R52 and R54, must connect to, and have power sourced solely by, a single protected 12VDC WAGO connector pair (i.e. the Load Terminals, as shown in Figure 8-9) of the one (1) CTR Electronics Power Distribution Panel, not the M6 cap screws.
- R48. All wiring and electrical devices, including all Control System COMPONENTS, shall be electrically isolated from the ROBOT frame. The ROBOT frame must not be used to carry electrical current.

R48 is checked by observing a  $>3k\Omega$  resistance between either the (+) or (-) post within the APP connector that is attached to the PDP and any point on the ROBOT.

The Victor-SP and Talon-SRX motor controller cases are electrically isolated. They may be mounted directly to ROBOT frame COMPONENTS.

Note that some cameras, decorative lights and sensors (e.g. the Axis 206 camera, some encoders, some IR sensors, etc.) have grounded enclosures. These devices must be electrically isolated from the ROBOT frame to ensure compliance with R48.

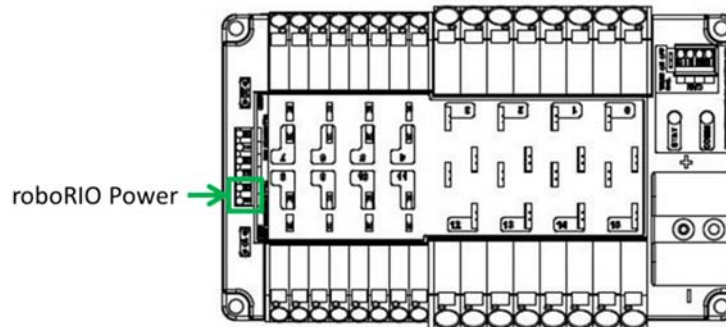
- R49. The 120A circuit breaker must be quickly and safely accessible from the exterior of the ROBOT. This is the only 120A circuit breaker allowed on the ROBOT.

Examples considered not “quickly and safely accessible” include breakers covered by an access panel or door, or mounted on, underneath or immediately adjacent to moving components.

It is strongly recommended that the 120A circuit breaker location be clearly and obviously labeled so it can be easily found by FIELD STAFF during a MATCH.

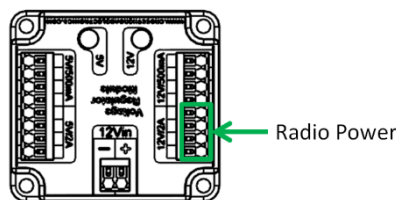
- R50.** The PDP, associated wiring, and all circuit breakers must be easily visible for Inspection.
- R51.** Any active electrical item that is not an actuator (specified in R33) or core Control System item (specified in R72) is considered a CUSTOM CIRCUIT. CUSTOM CIRCUITS shall not produce voltages exceeding 24V.
- R52.** The roboRIO power input must be connected to the dedicated supply terminals on the PDP shown in Figure 8-10. No other electrical load shall be connected to these terminals.

Figure 8-10: roboRIO power source



- R53.** The Wireless Bridge (Radio) power must be supplied directly by the 12V 2A output of a CTR Electronics Voltage Regulator Module (VRM) (P/N: am-2857, 217-4245) and must be the only load connected to those terminals.

Figure 8-11: Radio power source



Note that this wiring is different from the wiring for the radio used in 2015, but is identical to the wiring from 2016 and 2017. When using a 2015 VRM with the OM5P-AN or OM5P-AC radio, the radio should be connected as described above, not to the terminals labeled “Radio”.

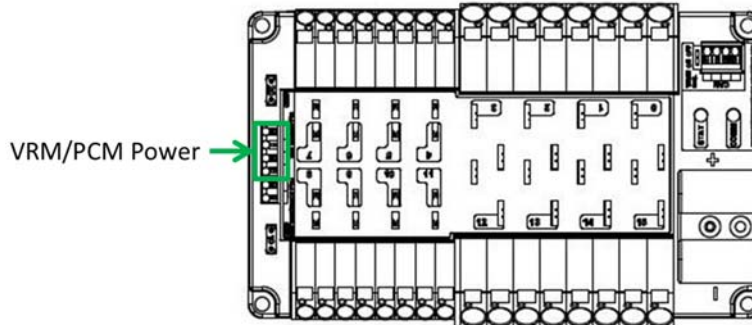
Note that this prohibits using any active POE Injector device to power the radio, but does not prohibit using any PASSIVE CONDUCTORS to inject the VRM power into an Ethernet cable plugged into the radio port labeled “18-24v POE”.

- R54.** The VRM supplying power to the Wireless Bridge per R53 must be connected to the designated supply terminals at the end of the PDP, and not the main WAGO connectors along the sides of



the PDP as shown in Figure 8-12. With the exception of a single CTR Electronics Pneumatics Control Module (PCM, P/N: am-2858), no other electrical load shall be connected to these PDP terminals.

Figure 8-12: VRM and PCM power source



Please reference [Wiring the FRC Control System](#) for Wireless Bridge wiring information.

**R55.** Only one wire shall be connected to each WAGO connector on the PDP.

If multi-point distribution of circuit power is needed (e.g. to provide power to multiple PCMs and/or VRMs from one 20A circuit), then all incoming wires may be appropriately spliced into the main lead (e.g. using an insulated terminal block, crimped splice or soldered wire splice), and the single main lead inserted into the WAGO connector to power the circuit.

**R56.** The only circuit breakers permitted for use in the PDP are:

- A. Snap Action VB3-A Series, terminal style F57
- B. Snap Action MX5-A or MX5-L Series, 40A rating or lower

**R57.** The fuses in the PDP shall only be replaced with functionally identical fuses (mini automotive blade fuses with values matching those printed on the PDP)

**R58.** Each branch circuit must be protected by one and only one circuit breaker on the PDP per Table 8-3. No other electrical load can be connected to the breaker supplying this circuit.

Table 8-3: Branch circuit protection requirements

Branch Circuit	Circuit Breaker Value	Quantity Allowed Per Breaker
Motor Controller	Up to 40A	1
CUSTOM CIRCUIT	Up to 40A	1
Fans permitted per Table 8-1 and not already part of COTS computing devices	Up to 20A	No limit
Relay Module	Up to 20A	1
PCM – with compressor	20A	1
Additional VRM (non-radio)/Additional PCM (non-compressor)	20A	3 total

R58 does not prohibit the use of smaller value breakers in the PDP or any fuses or breakers within CUSTOM CIRCUITS for additional protection.

- R59.** All circuits shall be wired with appropriately sized insulated copper wire (SIGNAL LEVEL cables don't have to be copper):

Table 8-4: Wire sizes

Application	Minimum Wire Size
31 – 40A protected circuit	12 AWG (13 SWG or 4 mm <sup>2</sup> )
21 – 30A protected circuit	14 AWG (16 SWG or 2.5 mm <sup>2</sup> )
6 – 20A protected circuit	18 AWG
Between the PDP dedicated terminals and the VRM or PCM Compressor outputs from the PCM	(19 SWG or 1 mm <sup>2</sup> )
Between the PDP and the roboRIO ≤5A protected circuit	22 AWG (22 SWG or 0.5 mm <sup>2</sup> )
VRM 2A circuits	24 AWG (24 SWG or .25mm <sup>2</sup> )
roboRIO PWM port outputs	26 AWG (27 SWG or 0.14 mm <sup>2</sup> )
SIGNAL LEVEL circuits (i.e. circuits which draw ≤1A continuous and have a source incapable of delivering >1A, including but not limited to roboRIO non-PWM outputs, CAN signals, PCM Solenoid outputs, VRM 500mA outputs and Arduino outputs)	28 AWG (29 SWG or .08 mm <sup>2</sup> )

Wires that are recommended by the device manufacturer or originally attached to legal devices are considered part of the device and by default legal. Such wires are exempt from R59.

- R60.** Branch circuits may include intermediate elements such as COTS connectors, splices, COTS flexible/rolling/sliding contacts, and COTS slip rings, as long as the entire electrical pathway is via appropriately gauged/rated elements.
- R61.** All non-SIGNAL LEVEL wiring with a constant polarity (i.e., except for outputs of relay modules, motor controllers, or sensors) shall be color-coded along their entire length from the manufacturer as follows:
- A.** Red, yellow, white, brown, or black-with-stripe on the positive (e.g. +24VDC, +12VDC, +5VDC, etc.) connections
  - B.** Black or blue for the common or negative side (-) of the connections.

Wires that are originally attached to legal devices are considered part of the device and by default legal. Ethernet cable used in POE cables may use a different color standard. Such wires are exempt from R61.

- R62.** CUSTOM CIRCUITS shall not directly alter the power pathways between the ROBOT battery, PDP, motor controllers, relays (per R35-B), motors and actuators (per R33), pneumatic solenoid valves, or other elements of the ROBOT control system (items explicitly mentioned in R72). Custom high impedance voltage monitoring or low impedance current monitoring circuitry connected to the ROBOT'S electrical system is acceptable, if the effect on the ROBOT outputs is inconsequential.

A noise filter may be wired across motor leads or PWM leads. Such filters will not be considered CUSTOM CIRCUITS and will not be considered a violation of R62 or R79.

Acceptable signal filters must be fully insulated and must be one of the following:

- A one microfarad (1  $\mu$ F) or less, non-polarized, capacitor may be applied across the power leads of any motor on your ROBOT (as close to the actual motor leads as reasonably possible).
- A resistor may be used as a shunt load for the PWM control signal feeding a servo.

## 8.8 Control, Command & Signals System

**R63.** ROBOTS must be controlled via one (1) programmable National Instruments roboRIO (P/N: am3000), with image version FRC\_2018\_v16 or later.

There are no rules that prohibit co-processors, provided commands originate from the roboRIO to configure, enable, and specify all operating points for all power regulating devices. This includes motor controllers legally wired to the CAN-bus.

**R64.** One (1) OpenMesh Wireless Bridge (P/N: OM5P-AN or OM5P-AC), that has been configured with the appropriate encryption key for your team number at each event, is the only permitted device for communicating to and from the ROBOT during the MATCH.

**R65.** The roboRIO Ethernet port must be connected to the Wireless Bridge port labeled “18-24 vPOE,” closest to the power connector (either directly, via a network switch, or via a CAT5 Ethernet pigtail).

Note: Placing a switch between the roboRIO and radio may impede the ability for FIELD STAFF to troubleshoot roboRIO connection issues on the FIELD. Teams may be asked to try directly connecting from the radio to roboRIO as part of troubleshooting efforts.

**R66.** Communication between the ROBOT and the OPERATOR CONSOLE is restricted as follows:

**A.** Network Ports:

- ii.** HTTP 80: Camera connected via switch on the ROBOT, bi-directional
- iii.** HTTP 443: Camera connected via switch on the ROBOT, bi-directional
- iv.** UDP/TCP 554: Real-Time Streaming Protocol for h.264 camera streaming, bi-directional
- v.** UDP 1130: Dashboard-to-ROBOT control data, uni-directional
- vi.** UDP 1140: ROBOT-to-Dashboard status data, uni-directional
- vii.** UDP/TCP 1180-1190: Camera data from the roboRIO to the Driver Station (DS) when the camera is connected the roboRIO via USB, bi-directional.
- viii.** TCP 1735: SmartDashboard, bi-directional
- ix.** UDP/TCP 5800-5810: Team Use, bi-directional

Teams may use these ports as they wish if they do not employ them as outlined above (i.e. TCP 1180 can be used to pass data back and forth between the ROBOT and the DS if the Team chooses not to use the camera on USB).

**B.** Bandwidth: no more than 7 Mbits/second.

Note that the 7 Mbit limit will be strictly enforced by the Wireless Bridge.

The [FMS Whitepaper](#) has more details on how to check and optimize bandwidth usage.

While *FIRST*® makes every effort to provide a wireless environment that allows teams access to a full 7 Mbits/second data rate (with about 100 Kbit used for ROBOT control and status), at some events wireless conditions may not accommodate this.

- R67.** The roboRIO, Driver Station software, and Wireless Bridge must be configured to correspond to the correct Team number, per the procedures defined in [Getting Started with the 2018 Control System](#).
- R68.** All signals must originate from the OPERATOR CONSOLE and be transmitted to the ROBOT via the ARCADE Ethernet network.
- R69.** No form of wireless communication shall be used to communicate to, from, or within the ROBOT, except those required per R64 and R68.

Devices that employ signals in the visual spectrum (e.g. cameras) and non-RF sensors that don't receive human-originated commands (e.g. "beam break" sensors or IR sensors on the ROBOT used to detect FIELD elements) aren't wireless communication devices and thus R69 doesn't apply.

- R70.** The Wireless Bridge must be mounted on the ROBOT such that the diagnostic lights are visible to ARCADE personnel.

Teams are encouraged to mount the wireless bridge away from noise generating devices such as motors, PCM(s), and VRM(s).

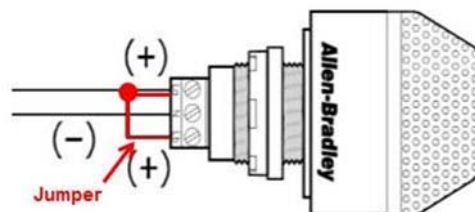
- R71.** ROBOTS must use at least one (1), but no more than two (2), diagnostic Robot Signal Lights (RSL) (P/N: 855PB-B12ME522).

Any RSL must be:

- A.** mounted on the ROBOT such that it is easily visible while standing three 3 ft. (~ 100 cm) in front of the ROBOT,
- B.** connected to the "RSL" supply terminals on the roboRIO,
- C.** wired for solid light operation, by placing a jumper between the "La" and "Lb" terminals on the light per Figure 8-13.

Please see [Wiring the 2018 FRC Control System](#) for connection details.

Figure 8-13: RSL jumper wiring





- R72.** The Driver Station software, roboRIO, Power Distribution Panel, Pneumatics Control Modules, Voltage Regulator Modules, RSL, 120A breaker, motor controllers, relay modules (per R35-B), Wireless Bridge, and batteries shall not be tampered with, modified, or adjusted in any way (tampering includes drilling, cutting, machining, rewiring, disassembling, painting, etc.), with the following exceptions:

Please note that the Driver Station application is a separate application from the Dashboard. The Driver Station software may not be modified, while teams are expected to customize their Dashboard code.

- A.** User programmable code in the roboRIO may be customized.
- B.** Motor controllers may be calibrated as described in owner's manuals.
- C.** Fans may be attached to motor controllers and may be powered from the power input terminals.
- D.** If powering the compressor, the fuse on a Spike H-Bridge Relay may be replaced with a 20A Snap-Action circuit breaker.
- E.** Wires, cables, and signal lines may be connected via the standard connection points provided on the devices.
- F.** Fasteners (including adhesives) may be used to attach the device to the OPERATOR CONSOLE or ROBOT or to secure cables to the device.
- G.** Thermal interface material may be used to improve heat conduction.
- H.** Labeling may be applied to indicate device purpose, connectivity, functional performance, etc.
- I.** Jumpers may be changed from their default location.
- J.** Limit switch jumpers may be removed from a Jaguar motor controller and a custom limit switch circuit may be substituted.
- K.** Device firmware may be updated with manufacturer supplied firmware.
- L.** Integral wires on the Victor SP, Victor SPX, or Talon SRX may be cut, stripped, and/or connectorized.
- M.** Devices may be repaired, provided the performance and specifications of the device after the repair are identical to those before the repair.
- N.** The cover may be removed from the Talon SRX data port.

Please note that while repairs are permitted, the allowance is independent of any manufacturer's warranty. Teams make repairs at their own risk and should assume that any warranty or RMA options are forfeited. Be aware that diagnosing and repairing COMPONENTS such as these can be difficult.

- R73.** Neither 12VDC power nor relay module or motor controller outputs shall be directly connected to the roboRIO (with the exception of the designated 12VDC input).
- R74.** Every relay module (per R35-B), servo controller, and PWM motor controller shall be connected to a corresponding port (relays to Relay ports, servo controllers and PWM controllers to PWM ports) on the roboRIO (either directly or through a WCP Spartan Sensor Board) or via a legal MXP connection (per R75). They shall not be controlled by signals from any other source, with the exception of the Nidec Dynamo motor controller which must also be connected to the roboRIO Digital I/O.



**R75.** If a motor is controlled via the MXP, its power regulating device must be connected by one of the following methods:

- A.** directly to any PWM pins,
- B.** via a network of PASSIVE CONDUCTORS used to extend the PWM pins, or
- C.** via one approved ACTIVE DEVICE:
  - i.** Kauai Labs navX MXP
  - ii.** RCAL MXP Daughterboard
  - iii.** REV Robotics RIOduino
  - iv.** REV Robotics Digit Board
  - v.** West Coast Products Spartan Sensor Board
  - vi.** Huskie Robotics HUSKIE 2.0 Board

A PASSIVE CONDUCTOR is any device or circuit whose capability is limited to the conduction and/or static regulation of the electrical energy applied to it (e.g. wire, splices, connectors, printed wiring board, etc.).

An ACTIVE DEVICE is any device capable of dynamically controlling and/or converting a source of electrical energy by the application of external electrical stimulus.

The “network of PASSIVE CONDUCTORS” only applies to the pins being used for PWM output to motors or servos. This means that connecting an ACTIVE DEVICE, such as a sensor to one MXP pin does not prevent other MXP pins from being used in accordance with R75-B.

**R76.** Each CAN motor controller must be controlled with signal inputs sourced from the roboRIO and passed via either a PWM (wired per R74) or CAN-bus (either directly or daisy-chained via another CAN-bus device) signal, but both shall not be wired simultaneously on the same device.

As long as the CAN bus is wired legally so that the heartbeat from the roboRIO is maintained, all closed loop control features of the CAN motor controller may be used. (That is, commands originating from the roboRIO to configure, enable, and specify an operating point for all CAN motor controller closed loop modes fit the intent of R63.

**R77.** Each PCM must be controlled with signal inputs sourced from the roboRIO and passed via a CAN-bus connection from the roboRIO (either directly or daisy-chained via another CAN-bus device).

**R78.** The PDP CAN interface must be connected to the CAN-bus on the roboRIO (either directly or daisy-chained via another CAN-bus device).

For documentation on how to wire the CAN-bus connections of the PDP see [Wiring the 2018 FRC Control System](#).

**R79.** The CAN-bus must be connected to the roboRIO CAN port.

- A.** Additional switches, sensor modules, CUSTOM CIRCUITS, third-party modules, etc. may also be placed on the CAN-bus.
- B.** No device that interferes with, alters, or blocks communications among the roboRIO and the PDP, PCMs, and/or CAN Motor Controllers on the bus will be permitted.



Only one wire should be inserted into each Weidmuller CAN connector terminal. For documentation on how to wire the CAN-bus connections of the roboRIO, PCM, PDP and CAN motor controllers, see [Wiring the FRC Control System](#).

## 8.9 Pneumatic System

---

**R80.** To satisfy multiple constraints associated with safety, consistency, Inspection, and constructive innovation, no pneumatic parts other than those explicitly permitted in [Section 8.9 Pneumatic System](#) shall be used on the ROBOT.

**R81.** All pneumatic items must be COTS pneumatic devices and either:

- A.** rated by their manufacturers for pressure of at least 125psi (~862 kPa), or
- B.** installed downstream of the primary relieving regulator (see R88), and rated for pressure of at least 70psi (~483 kPa)

Any pressure specification such as “working,” “operating,” “maximum,” etc. may be used to satisfy the requirements of R81.

It is recommended that all pneumatic items be rated by their manufacturers for a working pressure of at least 60 psi (~414 kPa).

**R82.** All pneumatic COMPONENTS must be used in their original, unaltered condition. Exceptions are as follows:

- A.** tubing may be cut,
- B.** wiring for pneumatic devices may be modified to interface with the control system,
- C.** assembling and connecting pneumatic COMPONENTS using the pre-existing threads, mounting brackets, quick-connect fittings, etc.,
- D.** removing the mounting pin from a pneumatic cylinder, provided the cylinder itself is not modified,
- E.** labeling applied to indicate device purpose, connectivity, functional performance, etc.

Do not, for example, paint, file, machine, or abrasively remove any part of a pneumatic COMPONENT – this would cause the part to become a prohibited item. Consider pneumatic COMPONENTS sacred.

**R83.** The only pneumatic system items permitted on ROBOTS include the items listed below.

- A.** Items available in the KOP (except as noted in K),
- B.** Pneumatic pressure vent plug valves functionally equivalent to those provided in the KOP,

Parker valves PV609-2 or MV709-2 are recommended.

- C.** Pressure relief valves functionally equivalent to those provided in the KOP,

Norgren 16-004-011, 16-004-003 or McMaster-Carr 48435K714 recommended.

To be considered functionally equivalent the valve must be preset or adjustable to 125 psi (~862 kPa) and capable of relieving at least 1 scfm (~472 cm<sup>3</sup>/s).

- D. Solenoid valves with a maximum  $\frac{1}{8}$  in. (nominal, ~6 mm) NPT, BSPP, or BSPT port diameter,
- E. Additional pneumatic tubing, with a maximum  $\frac{1}{4}$  in. (nominal, ~6 mm) outside diameter,
- F. Pressure transducers, pressure gauges, passive flow control valves (specifically “needle valve”), manifolds, and connecting fittings (including COTS pneumatic U-tubes),
- G. Check and quick exhaust valves, provided that the requirements of R95 are still met.
- H. Shutoff valves which relieve downstream pressure to atmosphere when closed (may also be known as 3-way or 3-way exhausting valves).
- I. Pressure regulators with the maximum outlet pressure adjusted to no more than 60 psi (~413 kPa),
- J. Pneumatic cylinders, pneumatic linear actuators, and rotary actuators,
- K. Pneumatic storage tanks (with the exception of White Clippard tanks P/N: AVT-PP-41), and
- L. Compressors compliant with R85.

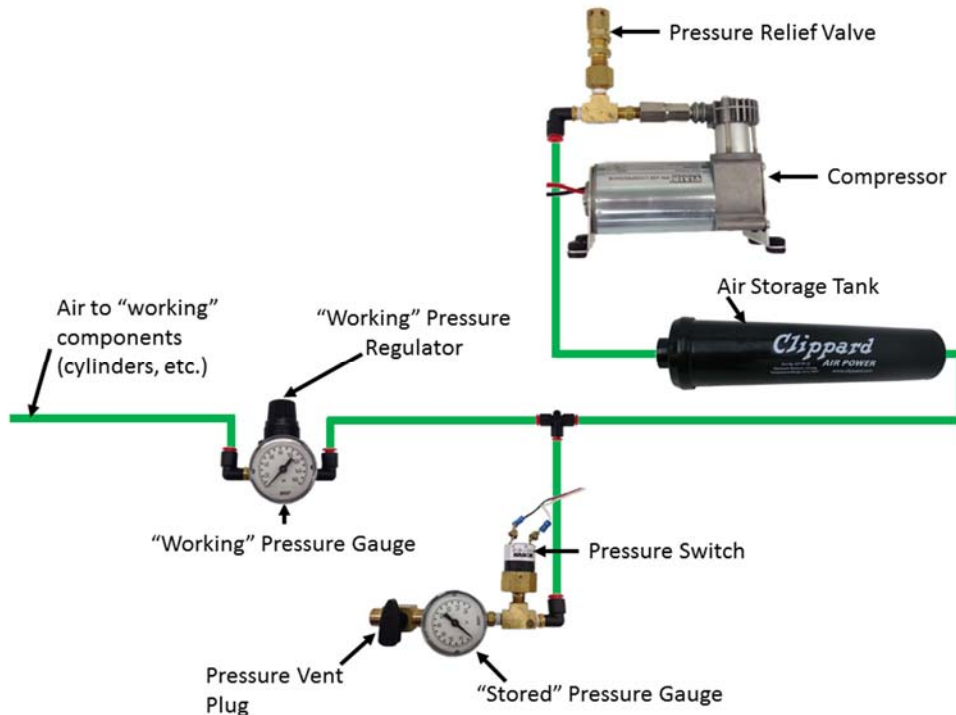
The following devices are not considered pneumatic devices and are not subject to pneumatic rules (though they must satisfy all other rules):

- A. a device that creates a vacuum
- B. closed-loop COTS pneumatic (gas) shocks
- C. air-filled (pneumatic) wheels
- D. pneumatic devices not used with pressurized air

**R84.** If pneumatic COMPONENTS are used, the following items are required as part of the pneumatic circuit and must be used in accordance with this section, as illustrated in Figure 8-14.

- A. One (1) FRC legal Compressor (per R85)
- B. Pressure relief valve (per R83-C) connected via legal rigid fittings (e.g. brass, nylon, etc.)
- C. Nason pressure switch, P/N SM-2B-115R/443
- D. At least one Pressure vent plug
- E. “Stored” pressure gauge (upstream from Primary Regulator, must show psi or kPa)
- F. “Working” pressure gauge (downstream from Primary Regulator, must show psi or kPa)
- G. “Working” pressure regulator

Figure 8-14: Pneumatic circuitry



- R85.** Throughout an event, compressed air on the ROBOT must be provided by its one compressor. Compressor specifications must not exceed nominal 1.10 cfm (~519 cm<sup>3</sup>/s) flow rate @ 12VDC.

A ROBOT'S compressor may be substituted by another compressor, but a ROBOT may only have one designated compressor at a time, and all compressed air on the ROBOT must be sourced from a single compressor.

For example, a team can't charge the circuit with an off-board compressor before the MATCH and then use a different on-board compressor to "top off" that circuit during the MATCH.

- R86.** The compressor (permitted per R85) may be located off-board the ROBOT, however the compressor must still be controlled and powered by the ROBOT when used.

The compressor may be mounted on the ROBOT, or it may be left off the ROBOT and used to pre-charge compressed air in storage tanks on the ROBOT provided the additional restrictions of R91 are met.

The intent of this rule is to permit teams to take advantage of the weight savings associated with keeping the compressor off-board. However, using the compressor off-board of the ROBOT does NOT permit non-compliance with any other applicable rules.

- R87.** "Stored" air pressure on the ROBOT must be no greater than 120 psi (~827 kPa). No stored air pressure intended for the ROBOT may be located off-board the ROBOT.
- R88.** "Working" air pressure on the ROBOT must be no greater than 60 psi (~413 kPa) and must be provided through a single primary adjustable, relieving, pressure regulator.

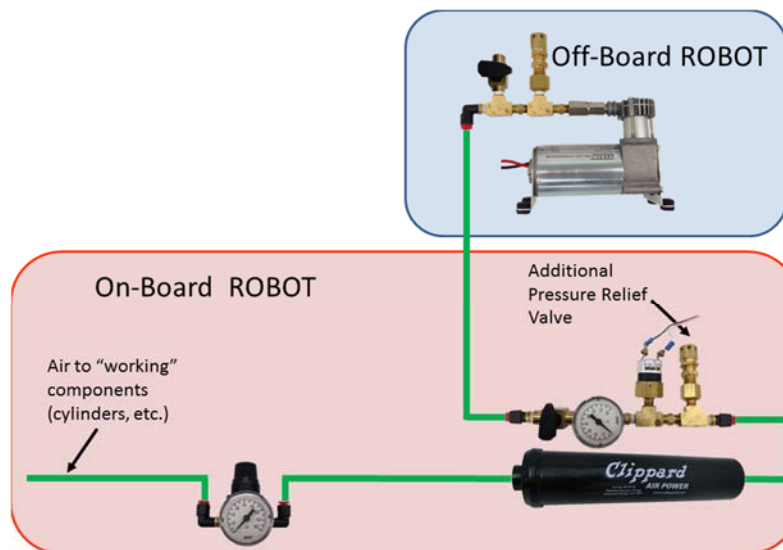
Norgren regulator P/N: R07-100-RNEA or Monnier P/N: 101-3002-1 recommended.

- R89.** Only the compressor, relief valve, pressure switch, pressure vent plug, pressure gauge, storage tanks, tubing, pressure transducers, and connecting fittings may be in the high-pressure pneumatic circuit upstream from the regulator.

It is recommended that all COMPONENTS in the high-pressure pneumatic circuit upstream from the regulator be rated for at least 115 psi (~793 kPa) working pressure.

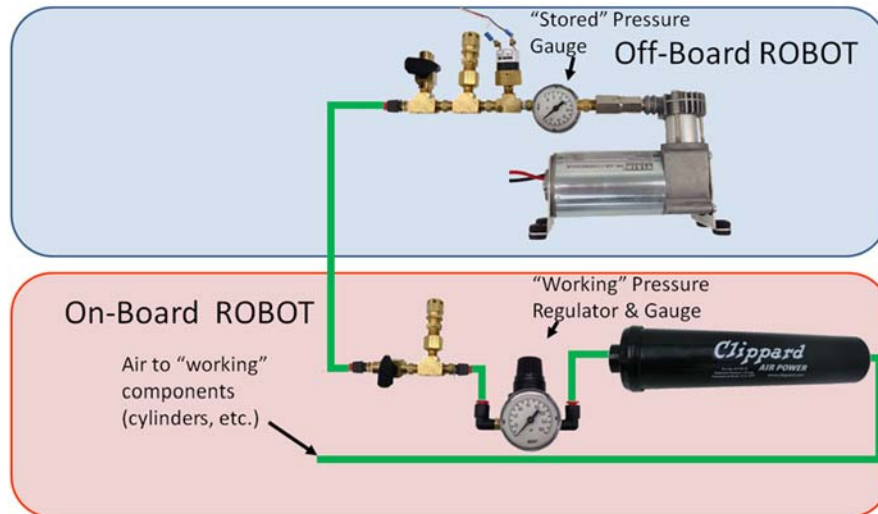
- R90.** Pressure gauges must be placed in easily visible locations upstream and downstream of the regulator to display the “stored” and “working” pressures.
- R91.** If the compressor is not included on the ROBOT (under the provisions of R87) the “stored” pressure gauge and pressure switch may be located on-board (Figure 8-15) or off-board (Figure 8-16) (but must be together), provided all other pneumatic rules are satisfied.

Figure 8-15: Off board compressor with stored pressure gauge and pressure switch on the ROBOT



- R92.** If the stored pressure gauge is kept off-board the ROBOT with the compressor, then only low-pressure (60 psi (~413 kPa) or less) “working” air can be stored on the ROBOT. The “working” pressure gauge must be installed on-board the ROBOT at all times (Figure 8-16).

Figure 8-16: Off board compressor with stored pressure gauge and pressure switch off the ROBOT



- R93.** The relief valve must be attached directly to the compressor or attached by legal hard fittings (e.g. brass, nylon, etc.) connected to the compressor output port. If using an off-board compressor, an additional relief valve must be included on the ROBOT.

Teams are required to check and/or adjust the relief valve to release air at 125 psi (~861 kPa). The valve may or may not have been calibrated prior to being supplied to Teams.

- R94.** The pressure switch requirements are:

- A.** It must be Nason P/N: SM-2B-115R/443
- B.** It must be connected to the high-pressure side of the pneumatic circuit (i.e. prior to the pressure regulator) to sense the “stored” pressure of the circuit.
- C.** The two wires from the pressure switch must be connected directly to the pressure switch input of the PCM controlling the compressor or, if controlled using the roboRIO and a Spike relay, to the roboRIO.
- D.** If connected to the roboRIO, the roboRIO must be programmed to sense the state of the switch and operate the relay module that powers the compressor to prevent over-pressuring the system.

- R95.** Any pressure vent plug must be:

- A.** connected to the pneumatic circuit such that, when manually operated, it will vent to the atmosphere to relieve all stored pressure in a reasonable amount of time, and
- B.** placed on the ROBOT so that it is visible and easily accessible.

If the compressor is not used on the ROBOT, then an additional pressure vent plug must be connected to the high-pressure portion of the pneumatic circuit off-board the ROBOT with the compressor (see R87).

- R96.** The outputs from multiple solenoid valves must not be plumbed together.

## 8.10 OPERATOR CONSOLE

- R97.** The Driver Station software provided on the [National Instruments website](#) is the only application permitted to specify and communicate the operating mode (i.e. Autonomous/Teleoperated) and operating state (Enable/Disable) to the ROBOT. The Driver Station software must be revision 18.0 or newer.

Teams are permitted to use a portable computing device of their choice (laptop computer, tablet, etc.) to host the DRIVER Station software while participating in competition MATCHES.

- R98.** The OPERATOR CONSOLE, the set of COMPONENTS and MECHANISMS used by the DRIVERS and/or HUMAN PLAYER to relay commands to the ROBOT, must include a graphic display to present the Driver Station diagnostic information. It must be positioned within the OPERATOR CONSOLE so that the screen display can be clearly seen during Inspection and in a MATCH.
- R99.** Devices hosting the Driver Station software must only interface with the Field Management System (FMS) via the Ethernet cable provided at the PLAYER STATION (e.g. not through a switch). Teams may connect the FMS Ethernet cable to their Driver Station device directly via an Ethernet pigtail, or with a single-port Ethernet converter (e.g. docking station, USB-Ethernet converter, Thunderbolt-Ethernet converter, etc.). The Ethernet port on the OPERATOR CONSOLE must be easily and quickly accessible.

Teams are strongly encouraged to use pigtails on the Ethernet port used to connect to the FMS. Such pigtails will reduce wear and tear on the device's port and, with proper strain relief employed, will protect the port from accidental damage.

- R100.** The OPERATOR CONSOLE must not
- A.** be longer than 60 in. (~152 cm)
  - B.** be deeper than 14 in. (~35 cm) (excluding any items that are held or worn by the DRIVERS during the MATCH)
  - C.** extend more than 6 ft. 6 in. (~198 cm) above the floor
  - D.** attach to the ARCADE (except as permitted by G19)

There is a 54 in. (~137 cm) long by 2 in. (nominal) wide strip of hook-and-loop tape ("loop" side) along the center of the PLAYER STATION support shelf that should be used to secure the OPERATOR CONSOLE to the shelf, per G19. See [Section 3.6.1 PLAYER STATION](#) for details.

Please note that while there is no hard weight limit, OPERATOR CONSOLES that weigh more than 30 lbs. (~13 kg.) will invite extra scrutiny as they are likely to present unsafe circumstances.

- R101.** Other than the system provided by the ARCADE, no other form of wireless communications shall be used to communicate to, from, or within the OPERATOR CONSOLE.

Examples of prohibited wireless systems include, but are not limited to, active wireless network cards and Bluetooth devices. For the case of the *FIRST* Robotics Competition, a motion sensing input device (e.g. Microsoft Kinect) is not considered wireless communication and is allowed.





**R102.** OPERATOR CONSOLES shall not be made using hazardous materials, be unsafe, cause an unsafe condition, or interfere with other DRIVE TEAMS or the operation of other ROBOTS.

